

Models

- 9008637 – Speed Scrub 15 in, AGM Battery
- 9008640 – Speed Scrub 15 in, Lithium-ion Battery
- 9016492 – Speed Scrub 15 in, AGM Battery w/ Iris

SPEED SCRUB®

15 in BATTERY FLOOR SCRUBBER
(S/N 10000000–20000000)

PARTS MANUAL

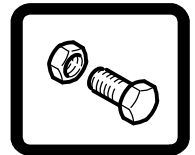
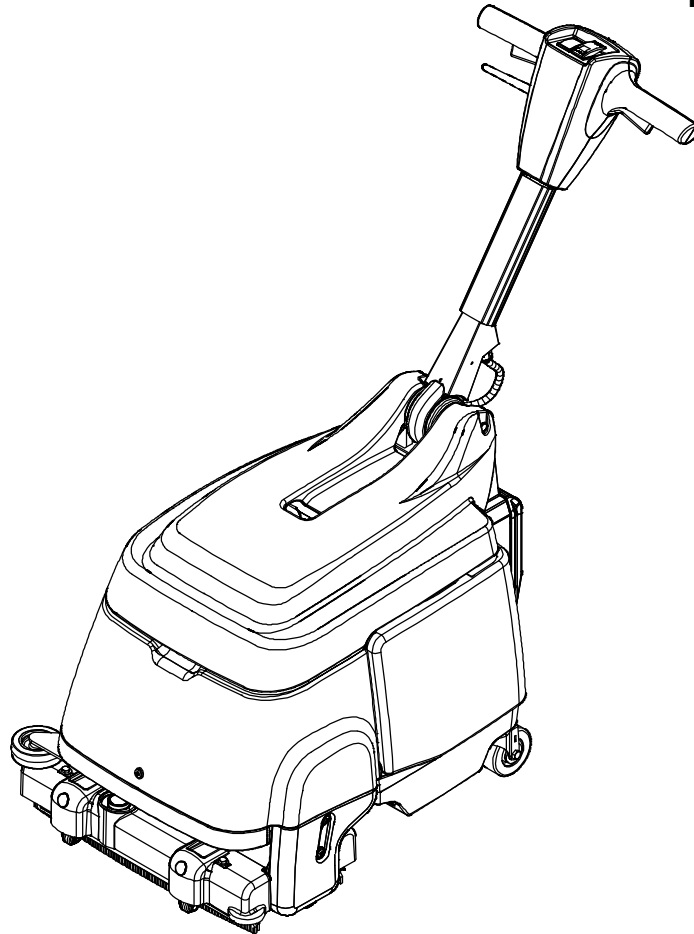

For the latest Parts manuals and other language Operator manuals, visit:

www.nobles.com/manuals

9008730
Rev. 08 (08-2024)



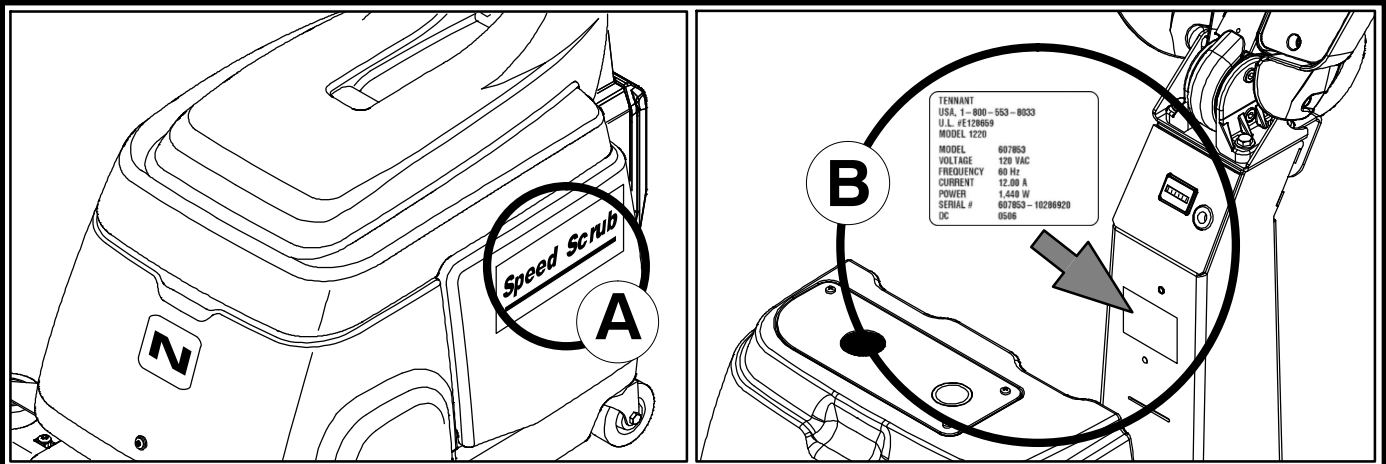

Ref	Part No.	Serial Number	Description	Qty.
1	82681	(000000—)	Bracket W/dt, Lpg Mount	1
▽ 2	63810	(000000—)	Latch Assy, Lpg Tank Mtg, W/Nut	4
▲ 3	51839	(000000—)	Nut Adjustable, Lpg Tank Mtg	2
4	49263	(000000—)	Tie, Cable	3
(D)	82556	(000000—001039)	Bracket, Vaporizer	1
	54930	(000000—)	Vaporizer, LPG	1

HOW TO ORDER PARTS – See diagram above

Only use TENNANT Company supplied or equivalent parts. Parts and supplies may be ordered online, by phone, by fax or by mail.

Follow the steps below to ensure prompt delivery.

1. (A) Identify the machine model.
2. (B) Identify the machine serial number from the data label.
3. (C) Ensure the proper serial number is used from the parts list.
4. Identify the part number and quantity.
Do not order by page or reference numbers.
5. Provide your name, company name, customer ID number, billing and shipping address, phone number and purchase order number.
6. Provide detail shipping instructions.

- (D) ▽ – identifies an assembly
 ▲ – identifies parts included in assembly

Please fill out at time of installation for future reference.

Model No. – _____

Serial No. – _____

Machine Options – _____

Sales Rep. – _____

Sales Rep. phone no. – _____

Customer ID Number – _____

Installation Date – _____

Tennant Company
 10400 Clean Street
 Eden Prairie, MN 55344-2650
 USA
 Phone: (800) 553-8033
 www.nobles.com

Specifications and parts are subject to change without notice.

Copyright © 2011 – 2024 TENNANT Company, Printed in U.S.A.

RECOMMENDED MAINTENANCE ITEMS

GENERAL RECOMMENDED MAINTENANCE
ITEMS 5

STANDARD PARTS

HANDLE GROUP 6
HANDLE MOUNT GROUP 8
FRAME GROUP 10
RECOVERY AND SOLUTION TANKS GROUP . 12
TANK COVER GROUP 14
VACUUM FAN GROUP 16
SCRUB HEAD GROUP 18
SCRUB HEAD LIFT GROUP 20
SOLUTION GROUP 22
SQUEEGEE GROUP, FRONT AND REAR 24
BATTERY AND CHARGER GROUP (LITHIUM) . 26
BATTERY AND CHARGER GROUP (AGM) 27
ELECTRICAL DIAGRAM, AGM BATTERY 28
ELECTRICAL DIAGRAM, LITHIUM BATTERY .. 31
ELECTRICAL DIAGRAM, IRIS TELEMETRY
OPTION 33
WIRE HARNESS, MAIN
(S/N 10984379 –) 34
WIRE HARNESS, MAIN
(S/N 10000000 – 10984378) 36
WIRE HARNESS, JUMPER (LITHIUM) 38
WIRE HARNESS, JUMPER (AGM)
(S/N 11067408 – 20000000) 39
WIRE HARNESS, JUMPER (AGM)
(S/N 10552859 – 11067407) 40
WIRE HARNESS, JUMPER (AGM)
(S/N 10000000 – 10552859) 41
WIRE HARNESS, IRIS TELEMETRY 42

OPTIONS

IRIS TELEMETRY GROUP 44
BATTERY CONVERSION KIT
(AGM TO LITHIUM) 46
BATTERY CONVERSION KIT
(LITHIUM TO AGM) 47
DOCUMENTATION GROUP (ONLINE ONLY) ... 48

RECOMMENDED MAINTENANCE ITEMS

RECOMMENDED MAINTENANCE ITEMS

GENERAL RECOMMENDED MAINTENANCE ITEMS

Ref.	Part No.	Serial Number	Description	Qty.
	1014918	(00000000-) Wheel, 03.0d 0.88w 0.31b, W/ Bshg, Rbr	3
	601443	(00000000-) Caster, Swivel, 3.0d 1.3w, .50-13 Stem	2
	9004283	(00000000-) Belt Kit, W/ Installation Tool	1
	1037197	(00000000-) Brush, Scrub, 89mm Od X 386mm, Nylon (Standard)	1
	1037277	(00000000-) Brush, Scrub, 89mm Od X 386mm, Poly (Optional)	1
	1037278	(00000000-) Brush, Scrub, 89mm Od X 386mm, Grit (Optional)	1
	9008581	(00000000-) Wheel Kit, Sqge, W/ Hdwr	1
	1064751	(00000000-) Blade Assy, Sqge, Ure, Cast, 4.2thk	2
	1049397	(00000000-) Blade Assy, Sqge, Ure, Millable	2
	1052876	(00000000-) Gasket, Tank	2

HANDLE GROUP

Ref.	Part No.	Serial Number	Description	Qty.
▽	1	9008682	(10000000-20000000) Handle Kit, Assy [Nob, Li+] (Li-Ion Model)	1
▽	1	9008683	(10000000-20000000) Handle Kit, Assy [Nob, Agm] (AGM Model)	1
▲	2	1048378	(10000000-20000000) Gauge, Voltmeter, 12vdc, Nominal (Li-Ion Model)	1
▲	2	1065438	(10000000-20000000) Gauge, Voltmeter, 12vdc Nominal [Agm] (AGM Model)	1
▲	3	1053503	(10000000-20000000) Switch, Rocker [Lighted] 12v Dpdt	1
▲▽	4	9008684	(10000000-20000000) Cover Kit, Front/Rear [Nob]	1
▲▲	5	1049028	(10000000-20000000) Label, Opertnl, Instrmt Panl	1
▲	6	1033893	(10000000-20000000) Lever, Cntrl, Switch	2
▲	7	1063165	(10000000-20000000) Switch, Push, Spst, No	1
▲	8	578430	(10000000-20000000) Washer, Flat, 0.50d, Pl [Spring-Disc]	2
▲	9	1043573	(10000000-20000000) Screw, #10-14 X 0.675, Spl[Shcs,Selftap]	7
▲	10	130175	(10000000-20000000) Plug, Hole, Rnd, 0.75d, Blk	1
▲	11	1043572	(10000000-20000000) Screw, #10-14 X 0.15, Spl[Shcs Selftap]	2
▲	12	1034945	(10000000-20000000) Lever, Adjmt, Handle	1
▲	13	222290	(10000000-20000000) Diode, Ele, Plug	1
▲	14	1034180	(10000000-20000000) Rod, Release	1
▲	15	1013295	(10000000-20000000) Spring, Cmpr [2100 Series]	1
▲	16	9006059	(10000000-20000000) Plunger Kit, Handle	1
	17	1016399	(10000000-20000000) Screw, Hex, M8 X 1.25 X 30, NI, Ss	4
	18	140027	(10000000-20000000) Washer, Flat, 0.35b 0.75d .04, Ss	4
▲	19	49609	(10000000-20000000) Screw, Soc, M8 X 1.25 X 16, 12.9	4
▲	20	1048219	(10000000-20000000) Bracket, Pivot, Cover, Mtg	1
▲	21	1000307	(10000000-20000000) Handle, Pivot, Half	2
▲	22	1053722	(10000000-20000000) Cordgrip, Str, Pg-11	1
▲	23	612422	(10000000-20000000) Seal, Org, Gear Seat	2
▲	24	1034872	(10000000-20000000) Gear, Lock, Handle	1
▲	25	1035681	(10000000-20000000) Screw, Pan, M5 X 0.80 X 12	1
▲	26	1034181	(10876910-20000000) Cover, Handle, Gray	1
▲	26	1036599	(10000000-10876909) Cover, Handle, Nobles	1
▲	27	1034176	(10000000-20000000) Bushing, Flng, 05mmb 12mmd 08mml [Pa6]	1
▲	28	1039088	(10000000-20000000) Label, Logo, 02.8l 3color [Nobles]	1

▽ ASSEMBLY

▲ INCLUDED IN ASSEMBLY

HANDLE MOUNT GROUP

355134

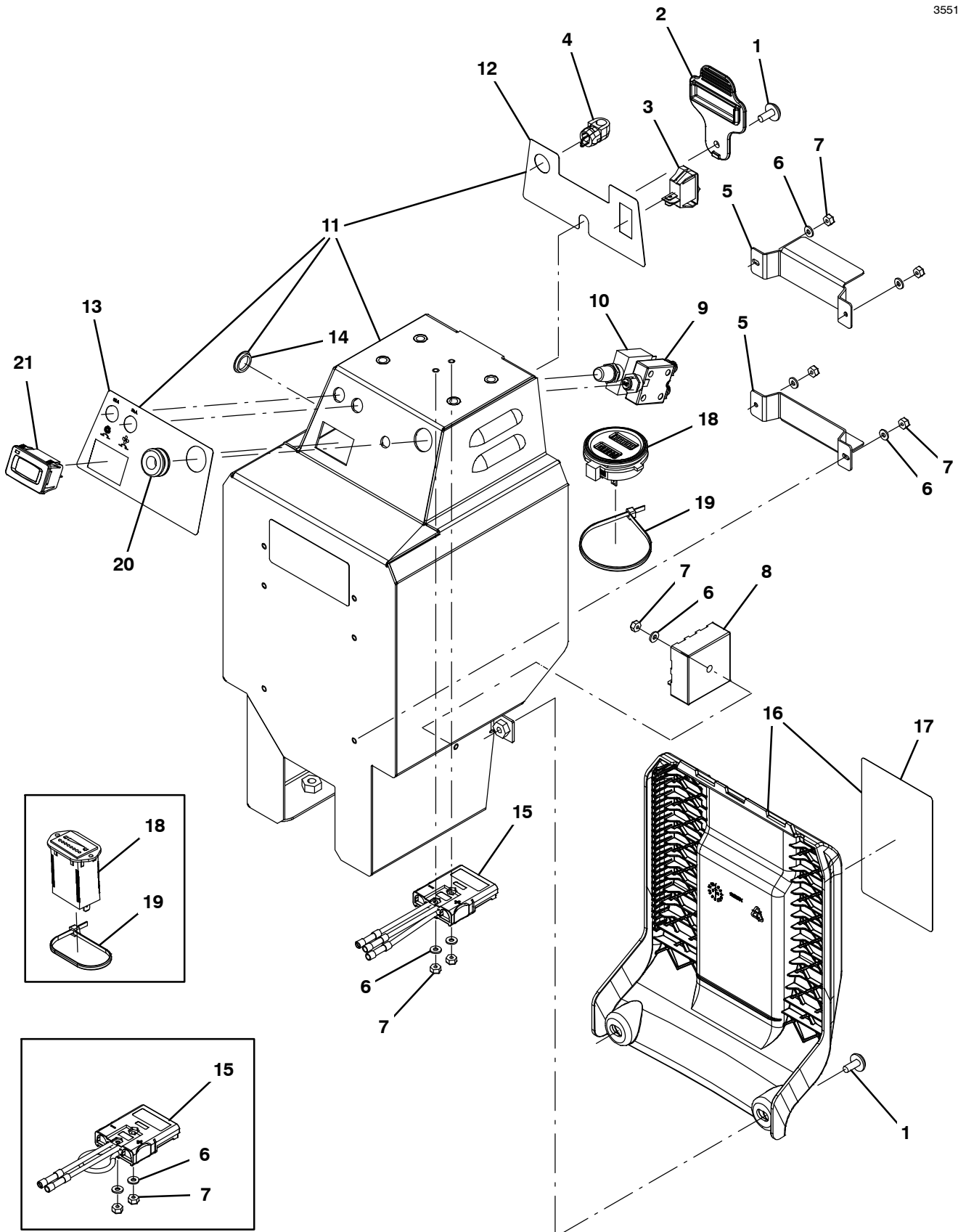

HANDLE MOUNT GROUP

Ref.	Part No.	Serial Number	Description	Qty.	
1	1019349	(10000000-20000000)	Screw, Trs, M6 X 1.00 X 16, Ss, Sems	3	
2	1048989	(10000000-20000000)	Cover, Chrgr Plug	1	
3	578005000	(10000000-20000000)	Switch, Rocker, Spst	1	
4	1049283	(10000000-20000000)	Strain Relief, Cord, Right Angle	1	
5	1059709	(10000000-20000000)	Channel, Stand-Off	2	
6	41578	(10000000-20000000)	Washer, Flat, 06, Ss	7	
7	75939	(10000000-20000000)	Nut, Hex, Lock, #06-32, NI	7	
8	1053209	(10000000-20000000)	Module, Timer, 12v, 5s Interval (Li-Ion Model)	1	
9	1067771	(10000000-20000000)	Circuitbreaker, 35.0a	1	
10	383725	(10000000-20000000)	Circuitbreaker, 30.0a, Resetable	1	
▽	11	9008687	(10000000-20000000)	Column Kit, Suppt, W/ Label	1
▲	12	1053739	(10000000-20000000)	Label, Opertnl, Instmt Panl, Lwr	1
▲	13	1065072	(10000000-20000000)	Label, Circuitbreaker [Conventional]	1
▲	14	57167	(10000000-20000000)	Plug, Hole, Rnd, 0.62h .03-.12, Blk Nyl (Non-Telemetry Models)	1
	15	9014799	(10000000-20000000)	Plug Kit, Chrgr, Repair, Mach Side	1
	15	1066279	(10000000-20000000)	Plug Kit, Chrgr, T1b [Psbs 75x] (Replaced By Kit 9014799)	1
▽	16	9008685	(10000000-20000000)	Cover Kit, Battery, W/Labels [Na]	1
▲	17	1049889	(10000000-20000000)	Label, Warning, Dc Scrubber	1
	18	1265929	(11067408-20000000)	Gauge, Hour, Battery(AGM Model)	1
	18	1064516	(10000000-11067407)	Indicator, Battery, 12vdc, 1.73volt/Cell (AGM Model) (Replaced By Kit 9022666)	1
	19	130773	(10000000-20000000)	Tie, Cable, Nyl, 11.0l, .14w, 3.0 Max. D (AGM Model)	1
	20	86726	(10000000-20000000)	Grommet, Rbr, 0.44id, F/0.5h, .19 Matl	1
	21	1064038	(10000000-20000000)	Gauge, Hourmeter, 05-277 Volt, Ac / Dc	1

▽ ASSEMBLY

▲ INCLUDED IN ASSEMBLY

FRAME GROUP

355136

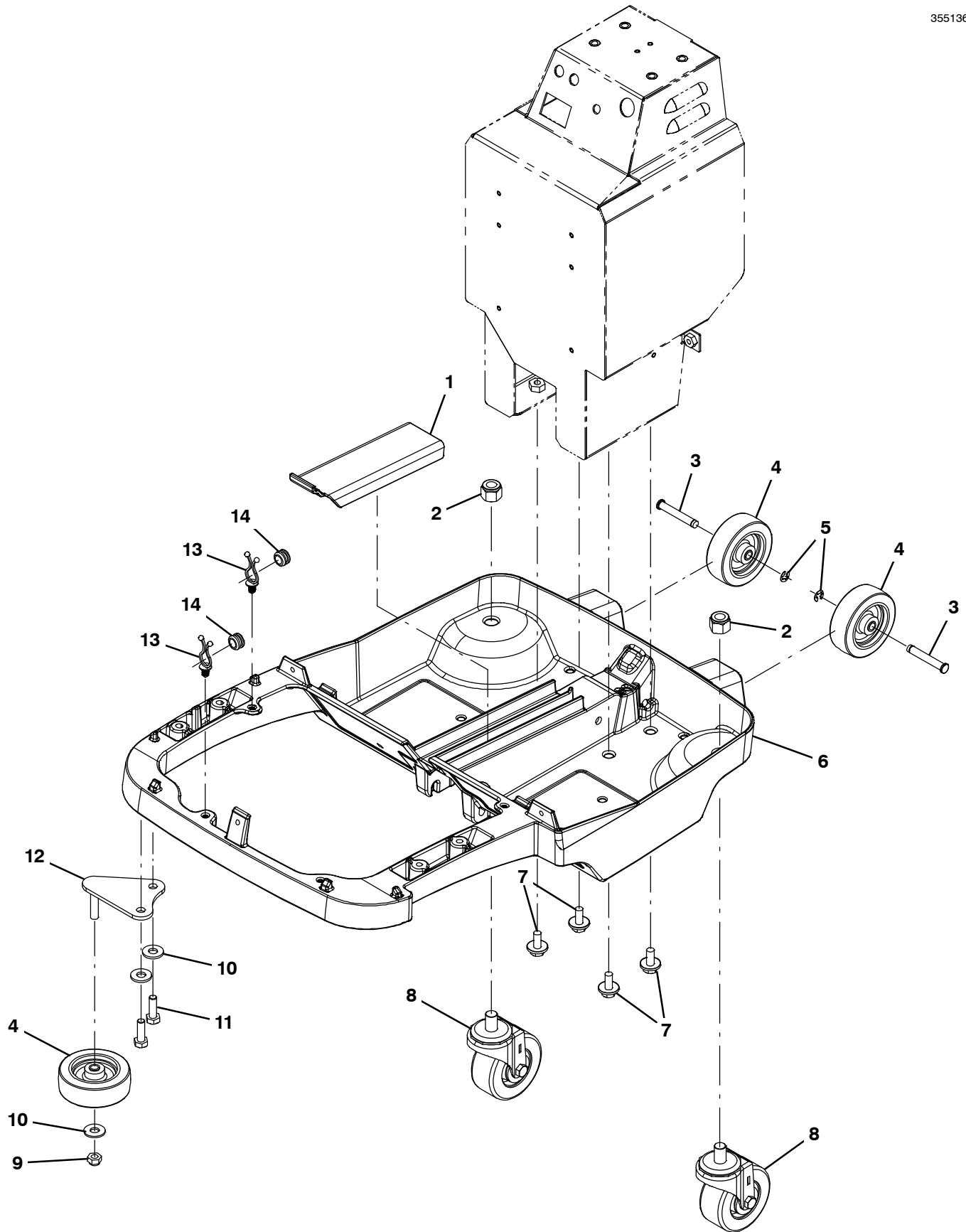

FRAME GROUP

Ref.	Part No.	Serial Number	Description	Qty.
1	1053149	(10000000-20000000)	Cover, Frame, Rear	1
2	02931	(10000000-20000000)	Nut, Hex, Lock, .50-13, NI, Ss	2
3	1035137	(10000000-20000000)	Pin, Clevis, Grvd 0.31d X 2.00l, Ss	2
4	1014918	(10000000-20000000)	Wheel, 03.0d 0.88w 0.31b, W/ Bshg, Rbr	3
5	1035139	(10000000-20000000)	Ring, Retaining, Ext, 0.31d, E-Type	2
6	1034013	(10000000-20000000)	Frame (Machined)	1
7	1020341	(10000000-20000000)	Screw, Hex, M8 X 1.25 X 20, Ss, Sems	4
8	601443	(10000000-20000000)	Caster, Swivel, 3.0d 1.3w, .50-13 Stem	2
9	08713	(10000000-20000000)	Nut, Hex, Lock, M8 X 1.25, NI, Ss	1
10	140027	(10000000-20000000)	Washer, Flat, 0.35b 0.75d .04, Ss	3
11	49826	(10000000-20000000)	Screw, Hex, M8 X 1.25 X 16, NI, Ss	2
12	1034805	(10000000-20000000)	Bracket, Bumper Wheel	1
13	30406	(10000000-20000000)	Clip, Keeper	2
14	10632-12	(10000000-20000000)	Grommet, Rbr, 0.38id, F/0.5h, .12 Matl	2

RECOVERY AND SOLUTION TANKS GROUP

355138

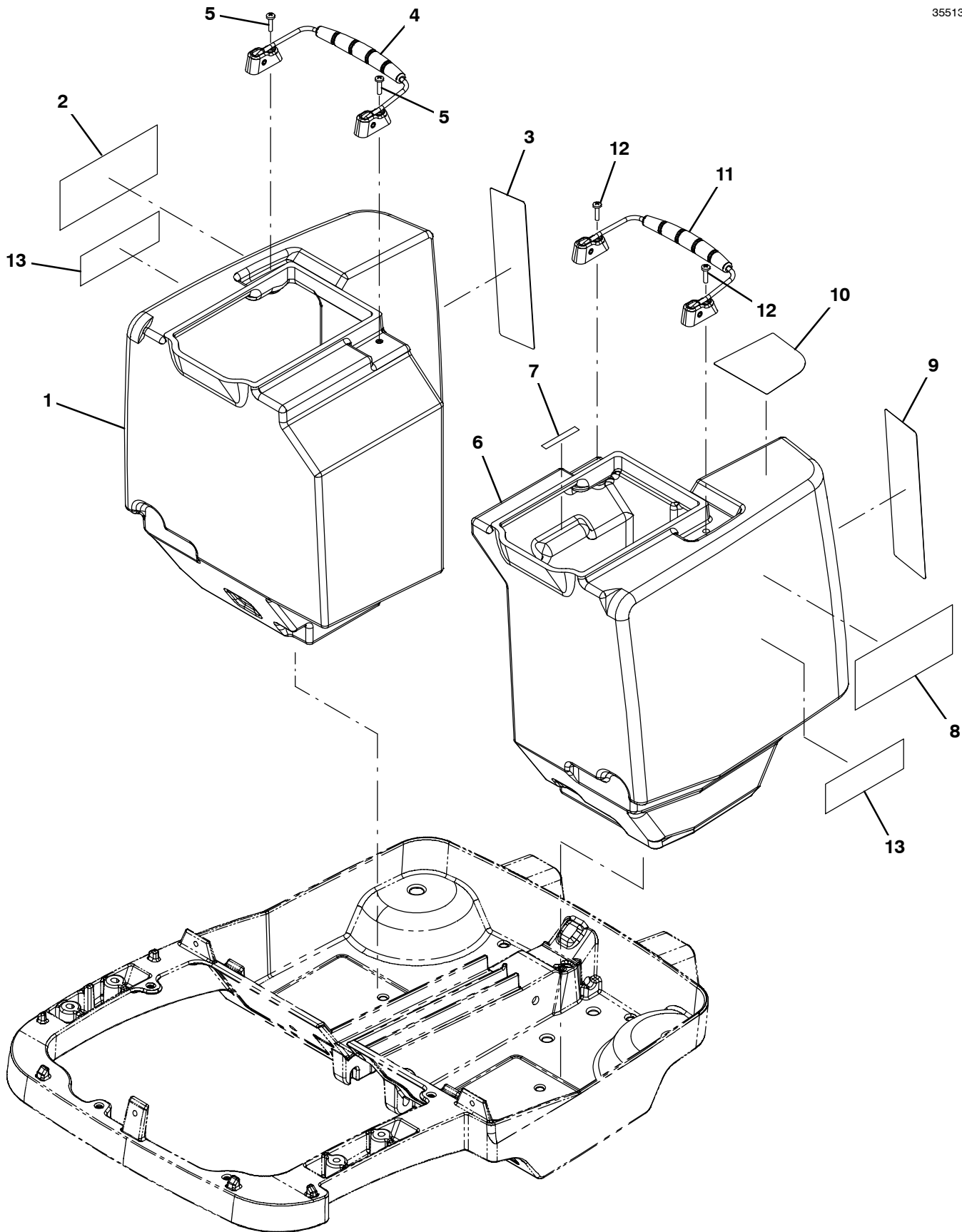

RECOVERY AND SOLUTION TANKS GROUP

Ref.	Part No.	Serial Number	Description	Qty.
▽	1	9016186	(10876910-20000000) Tank Kit, Recvy W/Labels [Gray Ss15 B]	1
▽	1	9008693	(10000000-10876909) Tank Kit, Recvy W/Labels [Ssb]	1
▲	2	1039498	(10000000-20000000) Label, Side [Speedscrub]	1
▲	3	1067554	(10000000-20000000) Label, Oprtn, Instr, Rh [T1b]	1
▲▽	4	9004285	(10000000-20000000) Handle Kit, Tank	1
▲▲	5	24265	(10000000-20000000) Screw, Pan, Phl, M4 X 0.70 X 16, Ss	2
▽	6	9016187	(10876910-20000000) Tank Kit, Soltn W/Labels [Gray Ss15 B]	1
▽	6	9008694	(10000000-10876909) Tank Kit, Soltn W/Labels [Ssb]	1
▲	7	1044865	(10000000-20000000) Label, Solution, Tank, Max. Fill, 3 Gal.	1
▲	8	1039498	(10000000-20000000) Label, Side [Speedscrub]	1
▲	9	1067553	(10000000-20000000) Label, Oprtn, Instr, Lh [T1b]	1
▲	10	1065771	(10000000-20000000) Label, Tank, Soltn	1
▲▽	11	9004285	(10000000-20000000) Handle Kit, Tank	1
▲▲	12	24265	(10000000-20000000) Screw, Pan, Phl, M4 X 0.70 X 16, Ss	2
	13	1066224	(10000000-20000000) Label, Lithium-Ion, Black [Speedscrub]	2

▽ ASSEMBLY

▲ INCLUDED IN ASSEMBLY

TANK COVER GROUP

355139

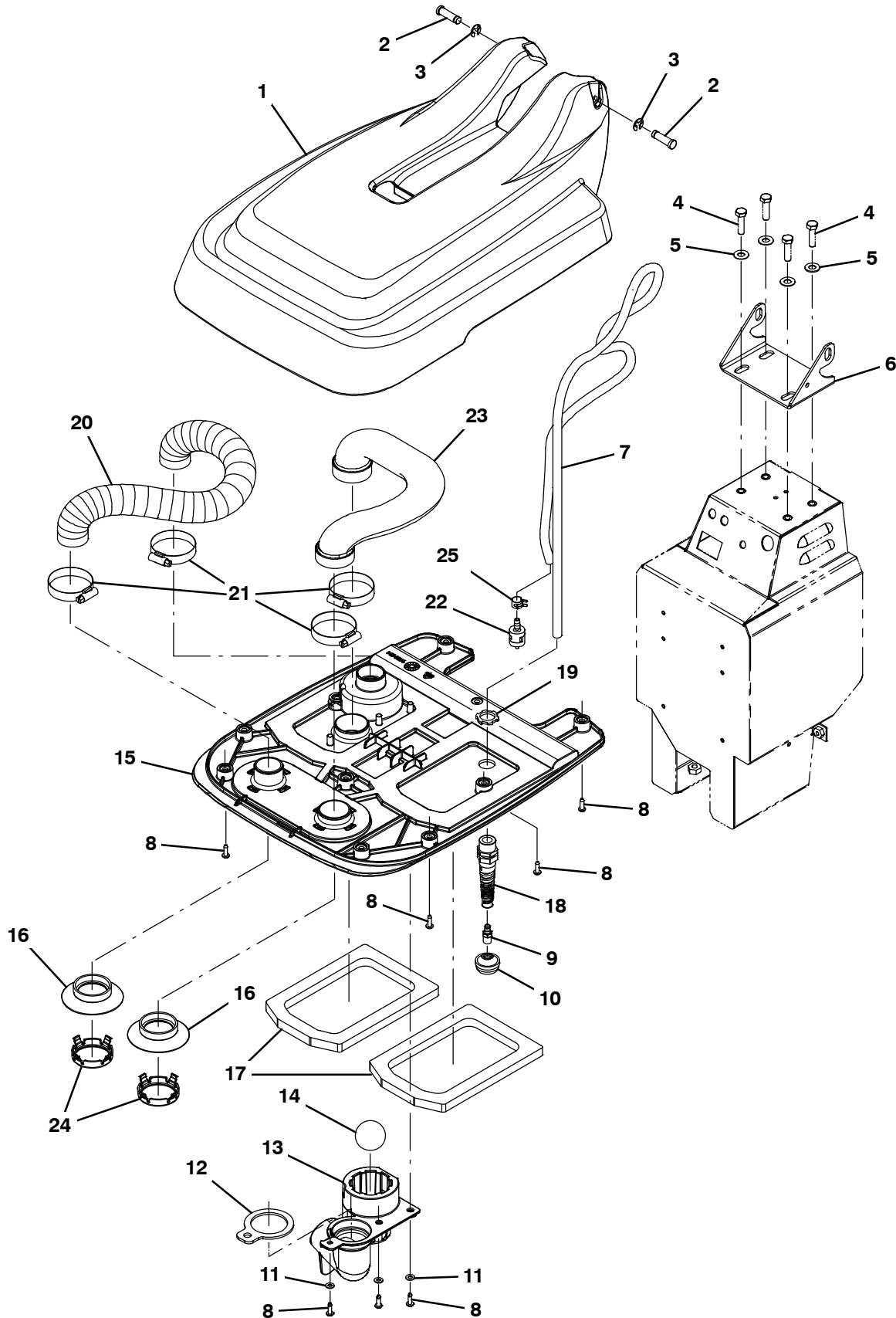

TANK COVER GROUP

Ref.	Part No.	Serial Number	Description	Qty.
1	1037759	(10000000-20000000)	Cover , Tanks, Upper, Nobles	1
2	1035358	(10000000-20000000)	Pin, Grvd, 0.375d, 1.25l	2
3	24555	(10000000-20000000)	Ring, Retaining, Ext, 0.38d, [E-Ring]	2
4	1016399	(10000000-20000000)	Screw, Hex, M8 X 1.25 X 30, NI, Ss	4
5	140027	(10000000-20000000)	Washer, Flat, 0.35b 0.75d .04, Ss	4
6	1034346	(10000000-20000000)	Bracket, Pivot, Cover, Mtg	1
7	1036063	(10000000-20000000)	Hose, Soltn, .25 Id, .453 Od, 56.0 L	1
8	140340	(10000000-20000000)	Screw, Pan, Phl, 10-24 X 0.62, Ss[Typ25]	13
9	1042715	(10000000-20000000)	Fitting, Brs, Str, Bm04/Pm02	1
10	1074694	(10000000-20000000)	Filter, Tube, Soltn, 200mesh	1
11	140011	(10000000-20000000)	Washer, Flat, 0.21b 0.45d .03, Ss	3
12	1051274	(10000000-20000000)	Gasket, Shield, Float	1
13	1042277	(10000000-20000000)	Shield, Float	1
14	1044370	(10000000-20000000)	Ball, Float, W/O Cage	1
15	1050434	(10000000-20000000)	Cover, Tank, Inner, Black	1
16	1036090	(10000000-20000000)	Seal, Vacuum [Trex]	2
17	1052876	(10000000-20000000)	Gasket, Tank	2
18	602849	(10000000-20000000)	Strainrelief, Cord, Ele, Pm08, Blk Nyl	1
19	140504	(10000000-20000000)	Nut, Lock, Conduit, Pm08	1
20	1037756	(10000000-20000000)	Hose, Vacuum, 1.5od, 18.0l [Wire-Reinf]	1
21	140308	(10000000-20000000)	Clamp, Hose, Wormdrive, 1.31-2.25d, .50w	4
22	1059000	(10000000-20000000)	Valve, Check, 0001psi Bm02/Bm04	1
23	1035866	(10000000-20000000)	Hose, Recvy, Formed [Trex]	1
24	1054345	(10000000-20000000)	Clip, Retaining, Seal	2
25	603654	(10000000-20000000)	Clamp, Hose, Ear, .44d [Ctb]	1

VACUUM FAN GROUP

355141

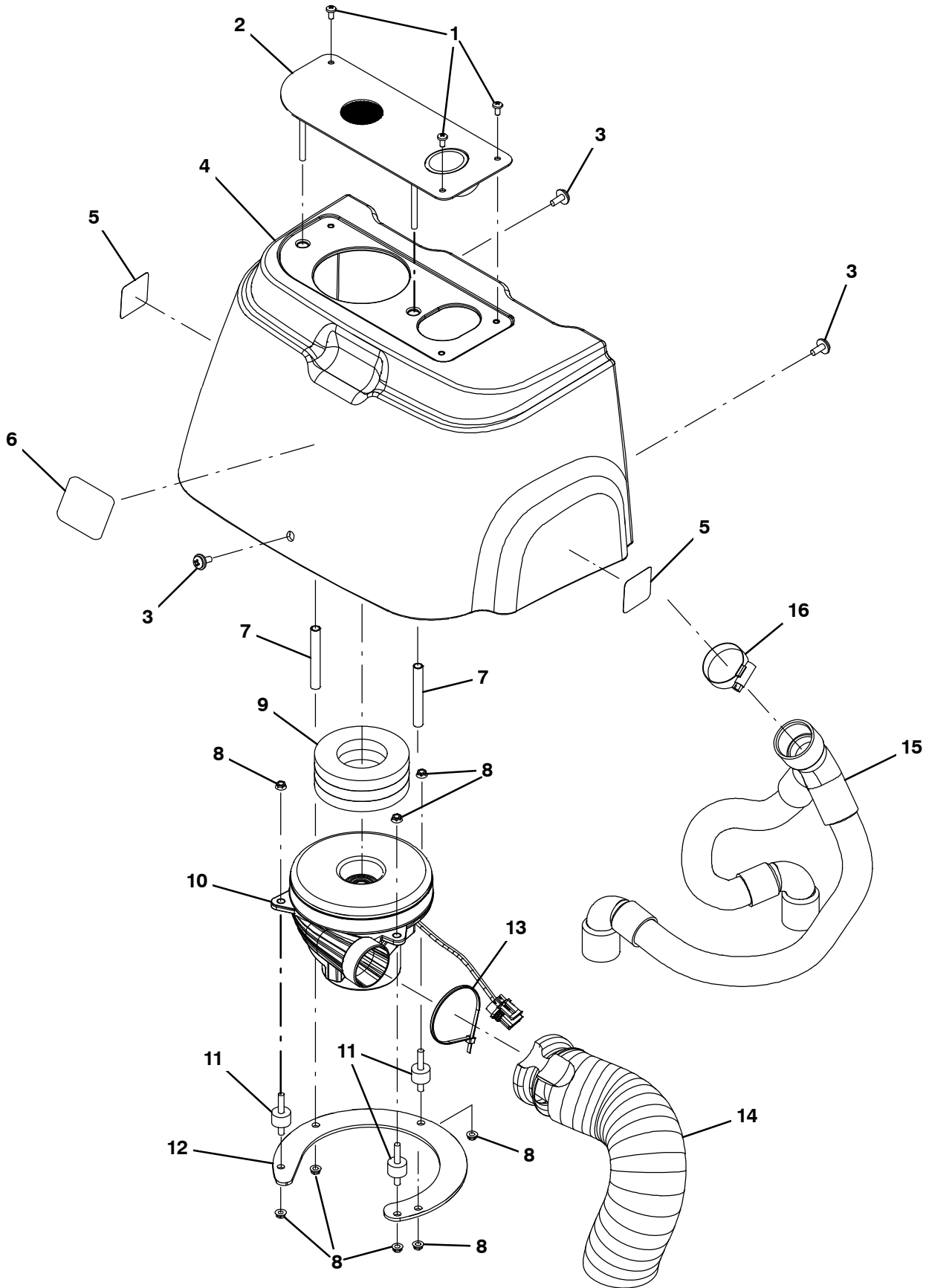

VACUUM FAN GROUP

Ref.	Part No.	Serial Number	Description	Qty.
1	1026454	(10000000-20000000)	Screw, Pan, Phl, M5 X 0.80 X 10, Ss	3
2	1048251	(10000000-20000000)	Wldt, Plate, Mtg, Vacuum	1
3	1019349	(10000000-20000000)	Screw, Trs, M6 X 1.00 X 16, Ss, Sems	3
▽	4	9004302	(10000000-20000000) Shroud Kit, W/ Labels [Nobles 3 Gal]	1
▲	5	578769	(10000000-20000000) Label, Parts, Moving [Textless]	2
▲	6	1034636	(10000000-20000000) Label, Front, 3.00 [Nobles Icon]	1
7	1050480	(10000000-20000000)	Spacer, 9.52od X 7.14id X 72.3l Ss	2
8	1040381	(10000000-20000000)	Nut, Hex, Flng, M6 X 1.0, Ss [Serrated]	8
9	1053269	(10000000-20000000)	Gasket, 38.1mm Th, 50.8mmid 95.25mmod	1
10	1048362	(10000000-20000000)	Fan, Vacuum, Domel	1
11	1011093	(10000000-20000000)	Isolator, Vib, .75d, M6 Stud Both Ends	3
12	1057236	(10000000-20000000)	Bracket, Mtg, Vacuum	1
13	130773	(10000000-20000000)	Tie, Cable, Nyl, 11.0l, .14w, 3.0 Max. D	1
14	390677	(10000000-20000000)	Muffler, Exhaust, Vacfan, Long	1
15	1067430	(10000000-20000000)	Hose Assy, Vacuum, Wye	1
16	11531	(10000000-20000000)	Clamp, Hose, Wormdrive, 1.06-2.00d, .56w	1

▽ ASSEMBLY

▲ INCLUDED IN ASSEMBLY

SCRUB HEAD GROUP

355142

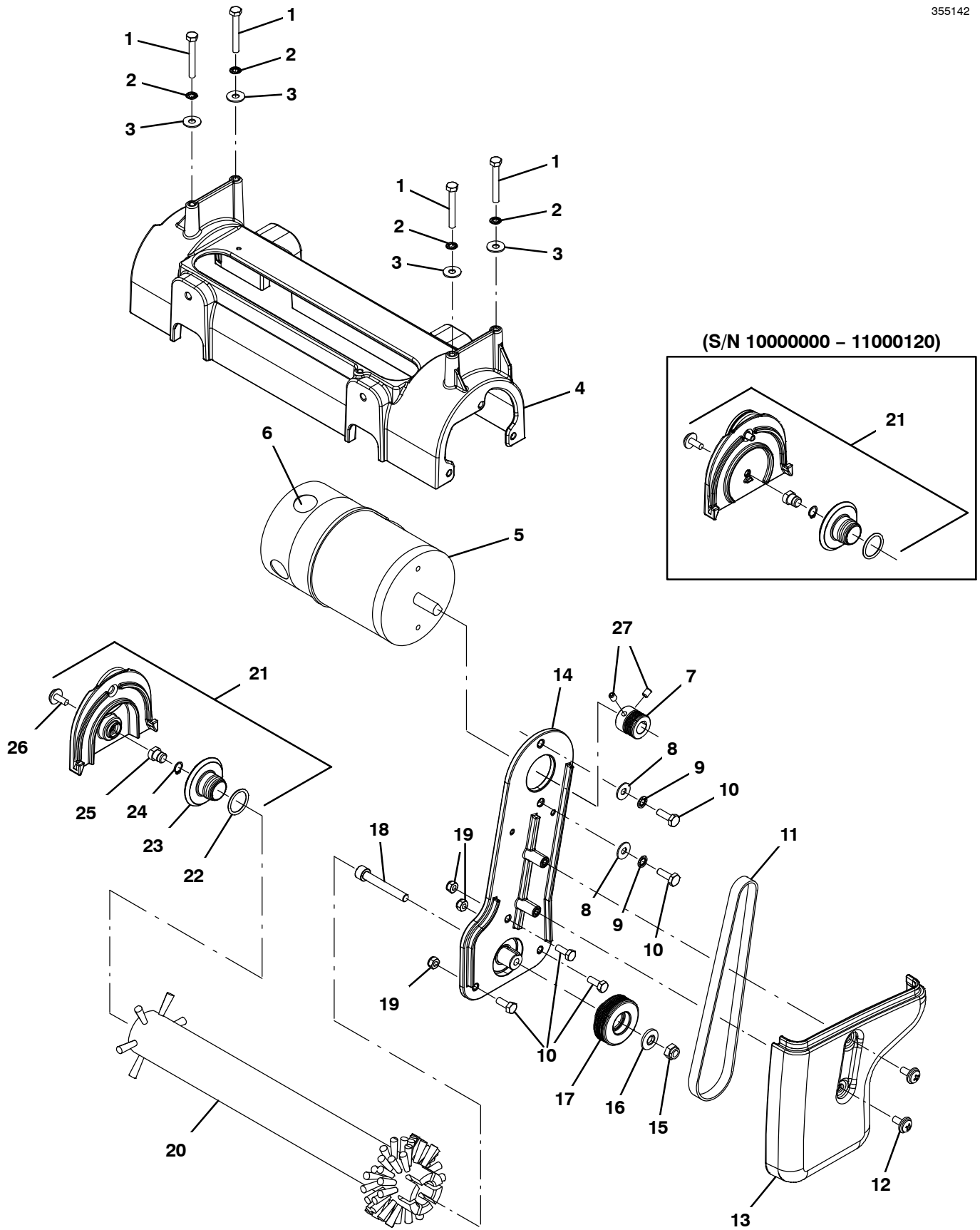

SCRUB HEAD GROUP

Ref.	Part No.	Serial Number	Description	Qty.
1	1045325	(10000000-20000000)	Screw, Hex, M6 X 1.00 X 45, Ss	4
2	07515	(10000000-20000000)	Washer, Lock, Int, 0.25, Ss	4
3	01684	(10000000-20000000)	Washer, Flat, 0.27b 0.69d .05, Ss	4
4	1034380	(10000000-20000000)	Housing, Brush, Sngl, 40cm	1
▽	5	1048393	(10000000-20000000) Motor, 12vdc, 3.98 Dia. X 6.5 L	1
▲	6	9008737	(10000000-20000000) Vr, Brush, Motor	1
7	1063530	(10000000-20000000)	Sheave, 07grv, 25.8pd [Ph]	1
8	01684	(10000000-20000000)	Washer, Flat, 0.27b 0.69d .05, Ss	2
9	07515	(10000000-20000000)	Washer, Lock, Int, 0.25, Ss	2
10	15678	(10000000-20000000)	Screw, Hex, .25-20 X 0.75, NI	5
11	9004283	(10000000-20000000)	Belt Kit, W/ Installation Tool	1
12	1019349	(10000000-20000000)	Screw, Trs, M6 X 1.00 X 16, Ss, Sems	2
13	1064397	(10000000-20000000)	Cover, Belt, Spg (Single Roller)	1
▽	14	9008296	(10000000-20000000) Bracket Kit, Motor Mount	1
▲	15	08713	(10000000-20000000) Nut, Hex, Lock, M8 X 1.25, NI, Ss	1
▲	16	41186	(10000000-20000000) Washer, Flat, Belleville, .31	1
▲	17	1030625	(10000000-20000000) Sheave, 07grv, 49.3pd	1
▲	18	1057476	(10000000-20000000) Screw, Soc, M8 X 1.25 X 55, Ss	1
19	08712	(10000000-20000000)	Nut, Hex, Lock, M6 X 1.00, NI, Ss	3
20	1037197	(10000000-20000000)	Brush, Scrub, 89mm Od X 386mm, Nylon (Standard)	1
20	1037277	(10000000-20000000)	Brush, Scrub, 89mm Od X 386mm, Poly (Optional)	1
20	1037278	(10000000-20000000)	Brush, Scrub, 89mm Od X 386mm, Grit (Optional)	1
▽	21	9007962	(10000000-20000000) Door Kit, Brush, W/ Hdwr (Includes Door & Hardware)	1
▲▽	9018438	(10000000-20000000)	Door Kit, Brush, Repair [T1b, E5] (Hardware Only - Does Not Include Door)	1
▲▲	22	1042312	(10000000-20000000) Seal, Org, .070 X .875 Id, 020	1
▲▲	23	1030680	(10000000-20000000) Hub, Idler, Brush	1
▲▲	24	01543	(10000000-20000000) Ring, Retaining, Ext, 0.39d, Basic	1
▲▲	25	1030682	(10000000-20000000) Shaft, Idler Plug	1
▲▲	26	1019349	(10000000-20000000) Screw, Trs, M6 X 1.00 X 16, Ss, Sems	1
27	09162	(10000000-20000000)	Screw, Set, Soc, M6 X 1.00 X 8, NI	2

▽ ASSEMBLY

▲ INCLUDED IN ASSEMBLY

SCRUB HEAD LIFT GROUP

355106

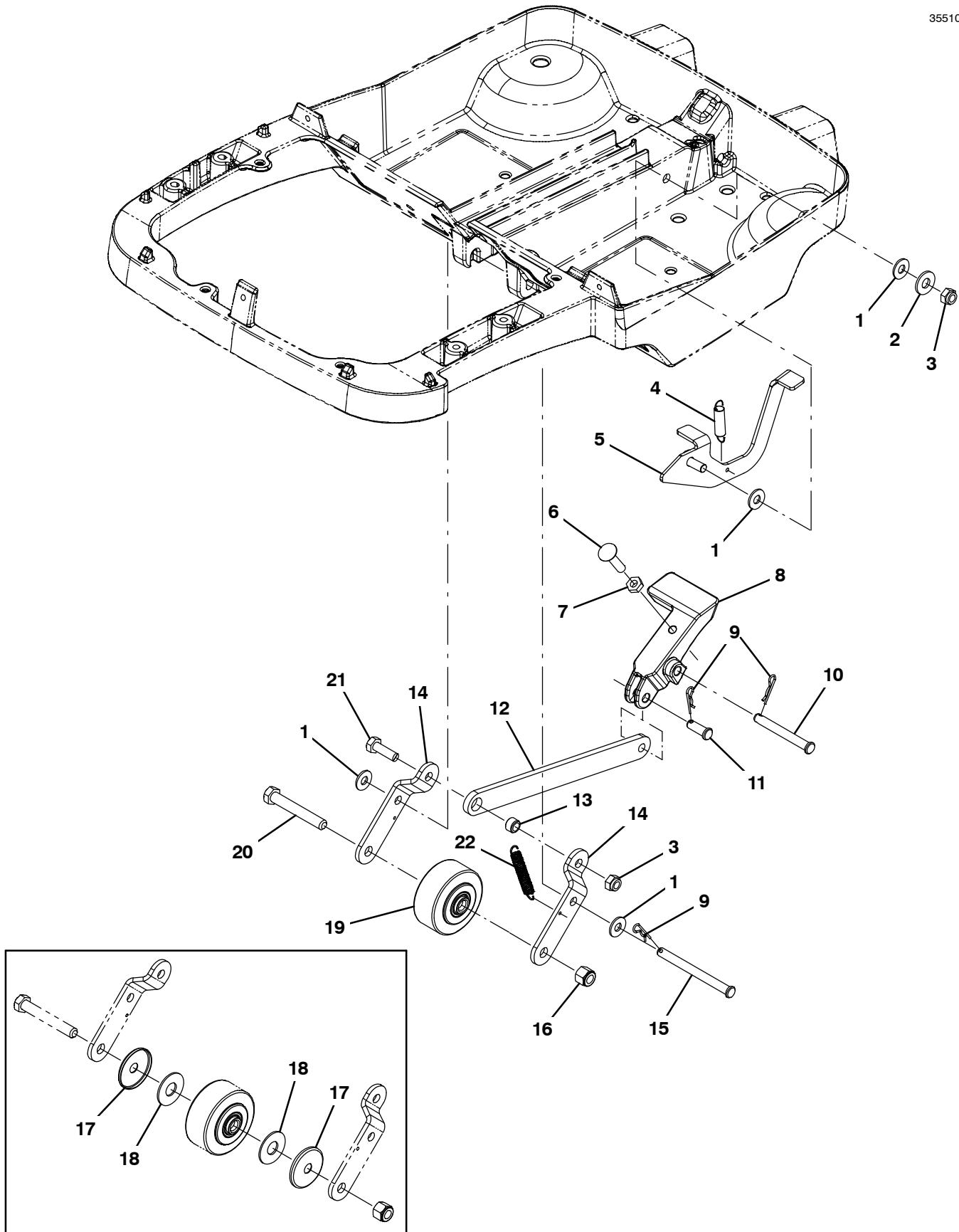

SCRUB HEAD LIFT GROUP

Ref.	Part No.	Serial Number	Description	Qty.
1	630446	(10000000-20000000)	Washer, Flat, 0.31b 0.75d .06, Nyl	3
2	140027	(10000000-20000000)	Washer, Flat, 0.35b 0.75d .04, Ss	1
3	08713	(10000000-20000000)	Nut, Hex, Lock, M8 X 1.25, NI, Ss	2
4	605812	(10000000-20000000)	Spring, Extn	1
5	1034420	(10000000-20000000)	Lever, Pedal, Wheel Release	1
6	1053751	(10000000-20000000)	Bolt, Carriage, .31-18 X 1.25, Ss	1
7	140548	(10000000-20000000)	Nut, Hex, Jam, Fin .31, Ss	1
8	1034376	(10000000-20000000)	Pedal, Foot	1
9	08085	(10000000-20000000)	Pin, Cotter, Hair, 0.31d .058 Wir	3
10	71274	(10000000-20000000)	Pin, Clevis, 0.31d X 2.62l	1
11	386987	(10000000-20000000)	Pin, Clevis, 0.31d X 0.88l	1
12	1034368	(10000000-20000000)	Arm, Linkage, Transport	1
13	222516	(10000000-20000000)	Sleeve, P/M, 0.32b 0.50d 0.3l [430ss]	1
14	1034371	(10000000-20000000)	Bracket, Transport, Wheel	2
15	1034513	(10000000-20000000)	Pin, Clevis, 0.31d X 3.50l	1
16	59156	(10000000-20000000)	Nut, Hex, Lock, .38-16, NI, Ss	1
17	1034351	(10000000-20000000)	Guard, Thread, Wheel (NLA - Replaced by 1034355)	2
18	140045	(10000000-20000000)	Washer, Flat, 0.51b 1.25d .06, Ss (NLA - Replaced by 1034355)	2
19	1034355	(10000000-20000000)	Wheel, 02.5d 1.25w 0.38b, Rbr, Gray	1
20	27992	(10000000-20000000)	Screw, Hex, .38-16 X 2.50, G5	1
21	09010	(10000000-20000000)	Screw, Hex, M8 X 1.25 X 25, Ss	1
22	140402	(10000000-20000000)	Spring, Extn, 0.375od 0.045wir 01.8l, Mw	1

SOLUTION GROUP

355143

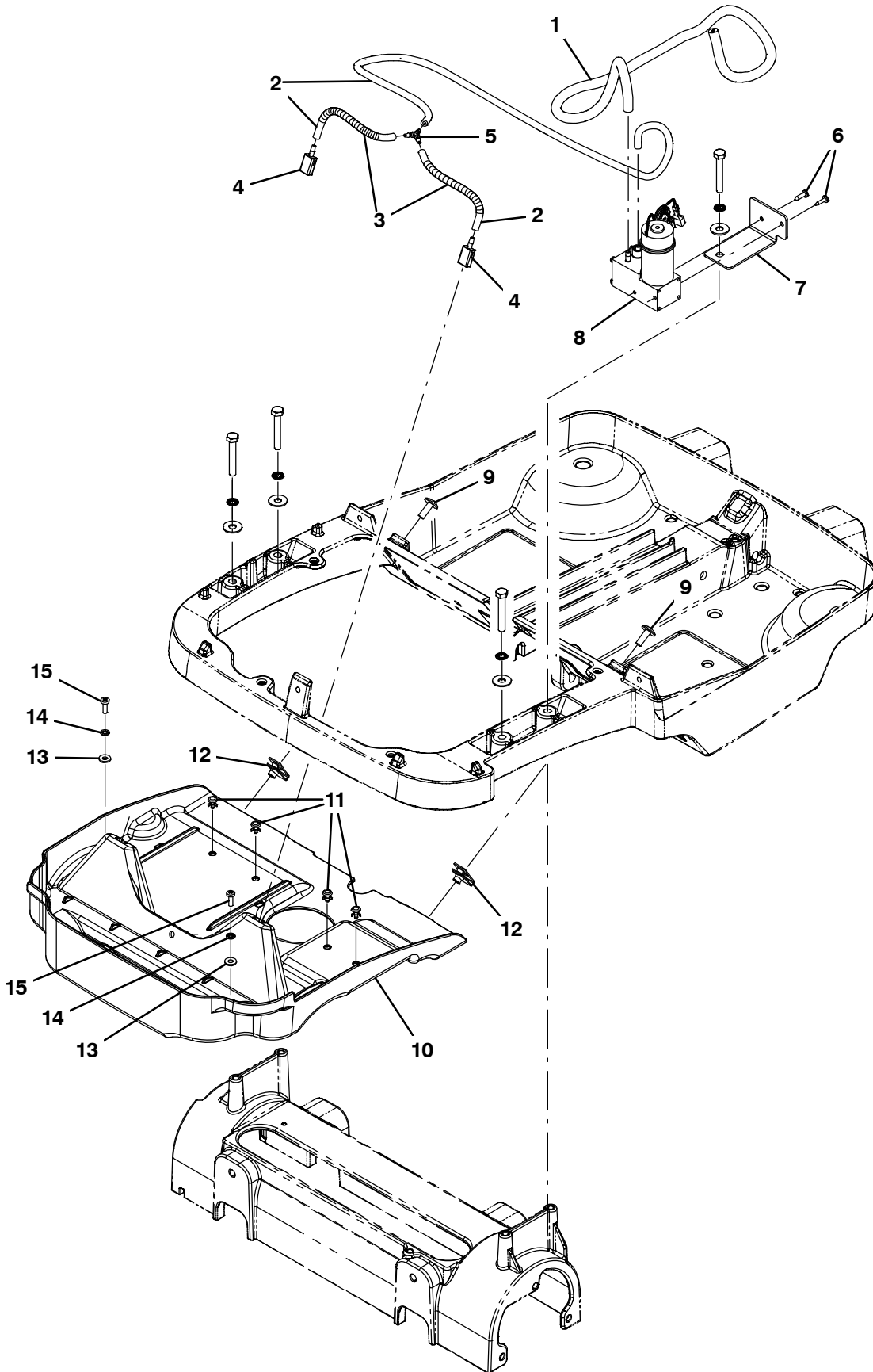

SOLUTION GROUP

Ref.	Part No.	Serial Number	Description	Qty.
1	9006630	(10000000-20000000)	Tube, 3.175 Id 9.0 Od 1120mm L	1
2	9006631	(10000000-20000000)	Tube, 1/8" Id, 780mm L	1
3	160123	(10000000-20000000)	Sleeve, Heatshrink, .025, Bulk	2
4	1049141	(10000000-20000000)	Nozzle, Fluidic	2
5	1055763	(10000000-20000000)	Fitting, Plstc, Y, Bm02/Bm02/Bm02	1
6	222267	(10000000-20000000)	Screw, Pan, Phl, 06-20 X 0.50, Fmg/Ab	2
7	1048289	(10000000-20000000)	Bracket, Mtg, Pump, Soltn	1
8	1048528	(10000000-20000000)	Pump, Diaphragm, Liquid	1
9	140824	(10000000-20000000)	Screw, Trs, .25-20 X 0.62, Phl, Ss	2
10	1067972	(10000000-20000000)	Shrd, Splash, Nozzle	1
11	578852	(10000000-20000000)	Rivet, Plstc, .200d X 0.20, Snap	4
12	82138	(10000000-20000000)	Nut, Spd, Clip, .25-20 [.025-.150]	2
13	41579	(10000000-20000000)	Washer, Flat, 08, Ss	2
14	02938	(10000000-20000000)	Washer, Lock, Int, 08, Ss	2
15	579237	(10000000-20000000)	Screw, Pan, Phl, M4 X 0.70 X 12, Ss	2

SQUEEGEE GROUP, FRONT AND REAR

355154

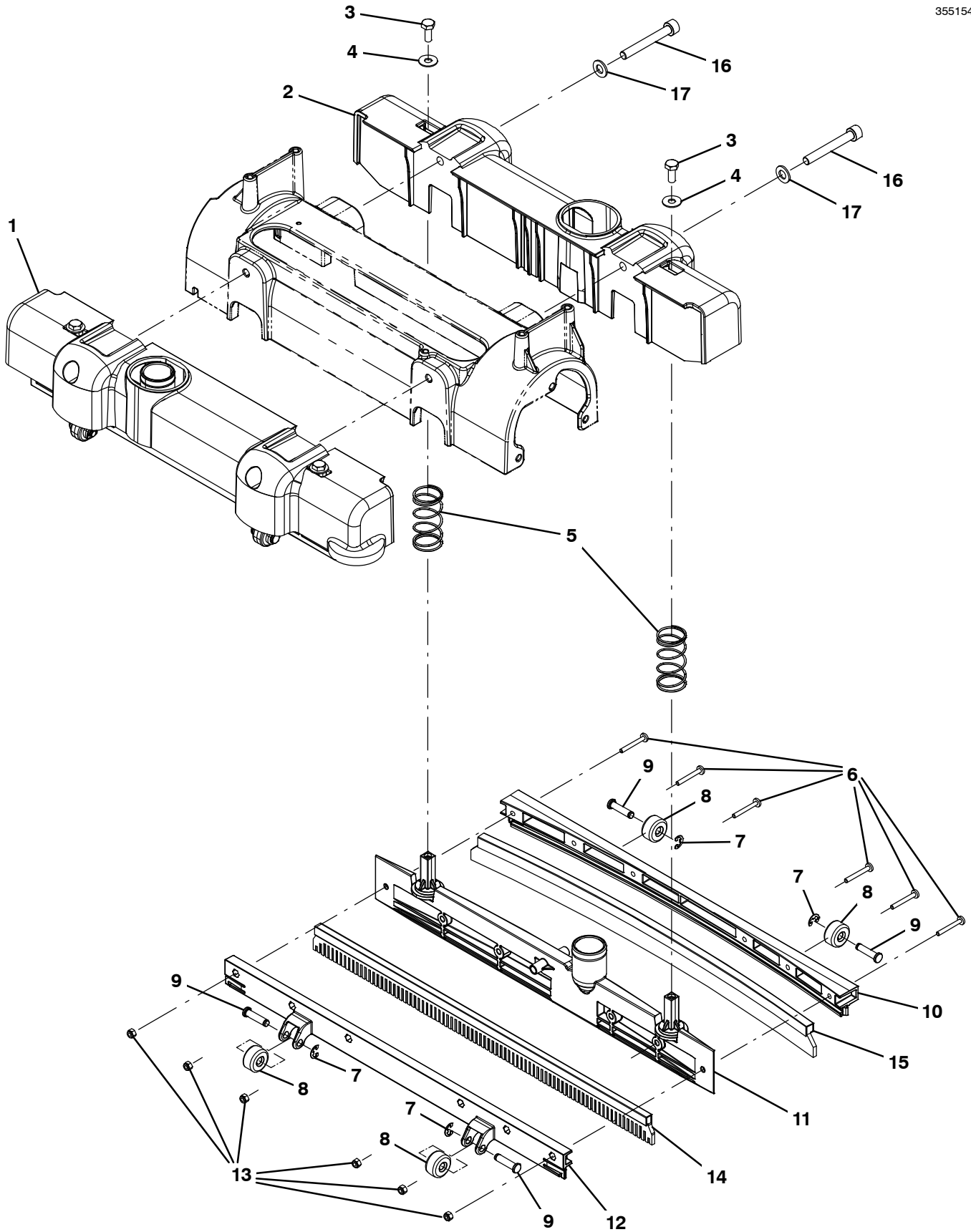

SQUEEGEE GROUP, FRONT AND REAR

Ref.	Part No.	Serial Number	Description	Qty.
▽	1	9009283	(10000000-20000000) Squeegee Assy [T1b Afmkt]	2
▲	2	1034109	(10000000-20000000) Housing, Squeegee	2
▲	3	01697	(10000000-20000000) Screw, Hex, .25-20 X 0.62, Ss	4
▲	4	01684	(10000000-20000000) Washer, Flat, 0.27b 0.69d .05, Ss	4
▲	5	1030427	(10000000-20000000) Spring, Cmpr, 0.92id .05wir 02.0l	4
▲	6	33931	(10000000-20000000) Screw, Pan, Phil, M4 X 0.70 X 30, Ss	12
▲▽		9008581	(10000000-20000000) Wheel Kit, Sqge, W/ Hdwr	1
▲▲	7	1035647	(10000000-20000000) Ring, Retaining, Ext, 0.25", [E-Ring]	8
▲▲	8	1030852	(10000000-20000000) Roller, Squeegee	8
▲▲	9	1065608	(10000000-20000000) Pin, Grv, 6.22d, 23.0l, Ss	8
▲	10	1049957	(10000000-20000000) Retainer, Squeegee, Outer	2
▲	11	1049358	(10000000-20000000) Frame, Sqge, 44cm [Newt]	2
▲	12	1057243	(10000000-20000000) Retainer, Squeegee, Inner	2
▲	13	33932	(10000000-20000000) Nut, Hex, Lock, M4 X 0.70, NI, Ss	12
	14	1245933	(10962018-20000000) Blade Assy, Sqge, Inner, Ure	2
	14	1049397	(10000000-10962017) Blade Assy, Sqge, Ure, Millable (Replaced By 1245933)	2
	15	1245932	(10962018-20000000) Blade Assy, Sqge, Outer, Ure	2
	15	1064751	(10000000-10962017) Blade Assy, Sqge, Ure, Cast, 4.2thk (Replaced By 1245932)	2
	16	09294	(10000000-20000000) Screw, Soc, M8 X 1.25 X 60, 12.9	4
	17	39349	(10000000-20000000) Washer, Flat, 0.31, Sae	4

▽ ASSEMBLY

▲ INCLUDED IN ASSEMBLY

BATTERY AND CHARGER GROUP (LITHIUM)

355144

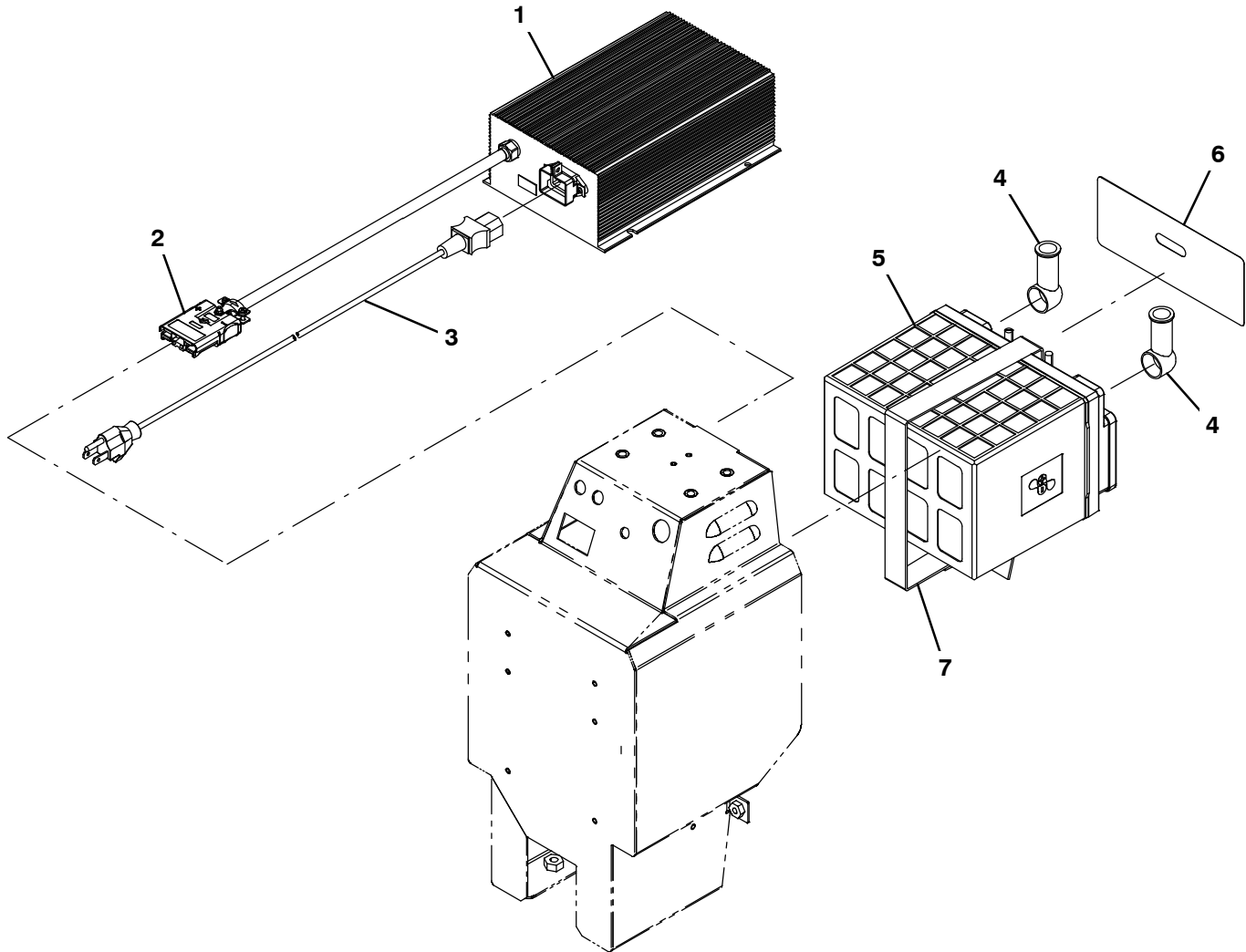

Ref.	Part No.	Serial Number	Description	Qty.	
1	1065754	(10000000-20000000)	Charger, 12vdc, 16a, 120/240vdc [Li-Ion]	1	
2	9022411	(10000000-20000000)	Plug Kit, Chrgr, Repair, Charger Side	1	
2	1066279	(10000000-20000000)	Plug Kit, Chrgr, T1b [Psbbs 75x] (Replaced By 9022411)	1	
3	1044067	(10000000-20000000)	Cord, Power, 16/3 Blk [2.5meter, Us/Jpn]	1	
3	1026325	(10000000-20000000)	Cord, Power, 1.0mm2/3 Blk[2.5meter, Aus]	1	
3	1044068	(10000000-20000000)	Cord, Power, Blk [2.5meter, Ce]	1	
3	1044069	(10000000-20000000)	Cord, Power, Blk [2.5meter, Uk]	1	
4	611221	(10000000-20000000)	Boot, Terminal, Battery, 25.4mm, Blk	2	
▽	5	9008690	(10000000-20000000)	Battery Replmt Kit, [Li+]	1
▲	6	1067699	(10000000-20000000)	Label, Battery, Li-Ion	1
	7	1065070	(10000000-20000000)	Strap, Poly, Webbing 1.0 X 28.0	1
	N/S	1063936	(10000000-20000000)	Harness, Jumper [Phantom Pi Lithium]	1

▽ ASSEMBLY

▲ INCLUDED IN ASSEMBLY

BATTERY AND CHARGER GROUP (AGM)

355145

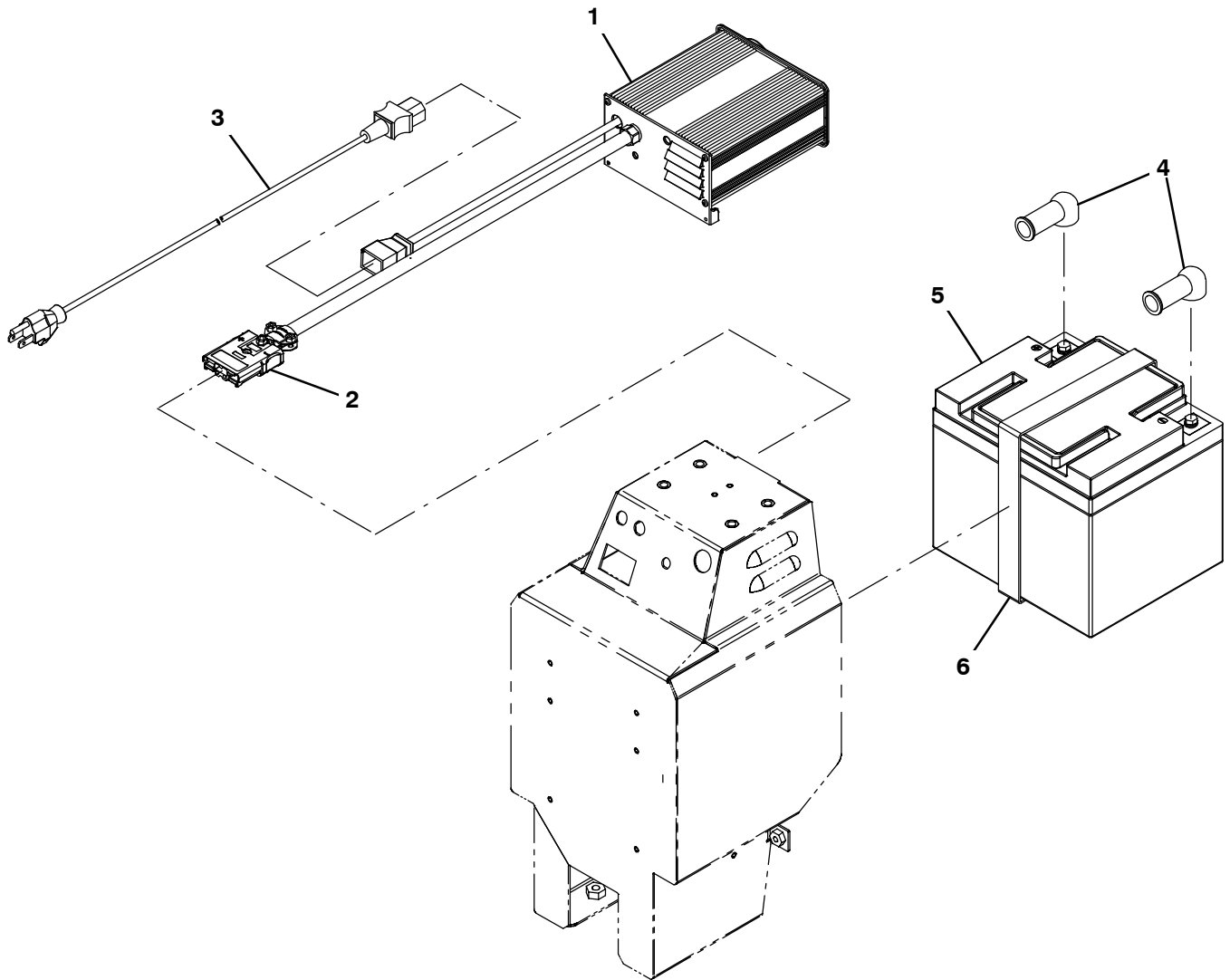

Ref.	Part No.	Serial Number	Description	Qty.
1	1067790	(10000000-20000000)	Charger, Battery, 12vdc [Spe Eu & Na]	1
2	9022411	(10000000-20000000)	Plug Kit, Chrgr, Repair, Charger Side	1
2	1066279	(10000000-20000000)	Plug Kit, Chrgr, T1b [Psb5 75x] (Replaced By 9022411)	1
3	1044067	(10000000-20000000)	Cord, Power, 16/3 Blk [2.5meter, Us/Jpn]	1
3	1026325	(10000000-20000000)	Cord, Power, 1.0mm2/3 Blk[2.5meter, Aus]	1
3	1044068	(10000000-20000000)	Cord, Power, Blk [2.5meter, Ce]	1
3	1044069	(10000000-20000000)	Cord, Power, Blk [2.5meter, UK]	1
4	611221	(10000000-20000000)	Boot, Terminal, Battery, 25.4mm, Blk	2
5	1065086	(10000000-20000000)	Battery, 12vdc 0050ah	1
6	1065070	(10000000-20000000)	Strap, Poly, Webbing 1.0 X 28.0	1
N/S	1266170	(11067408-20000000)	Harness, Ele, Jumper [Phantom Agm/Tpp]	1
N/S	1069703	(10552860-11067407)	Harness, Jumper [Phantom Agm / Tpp]	1
N/S	1064899	(10000000-10552859)	Harness, Jumper [Phantom Agm / Tpp] (Replaced by 1069703)	1

ELECTRICAL DIAGRAM, AGM BATTERY (Page 1 of 3)

355271

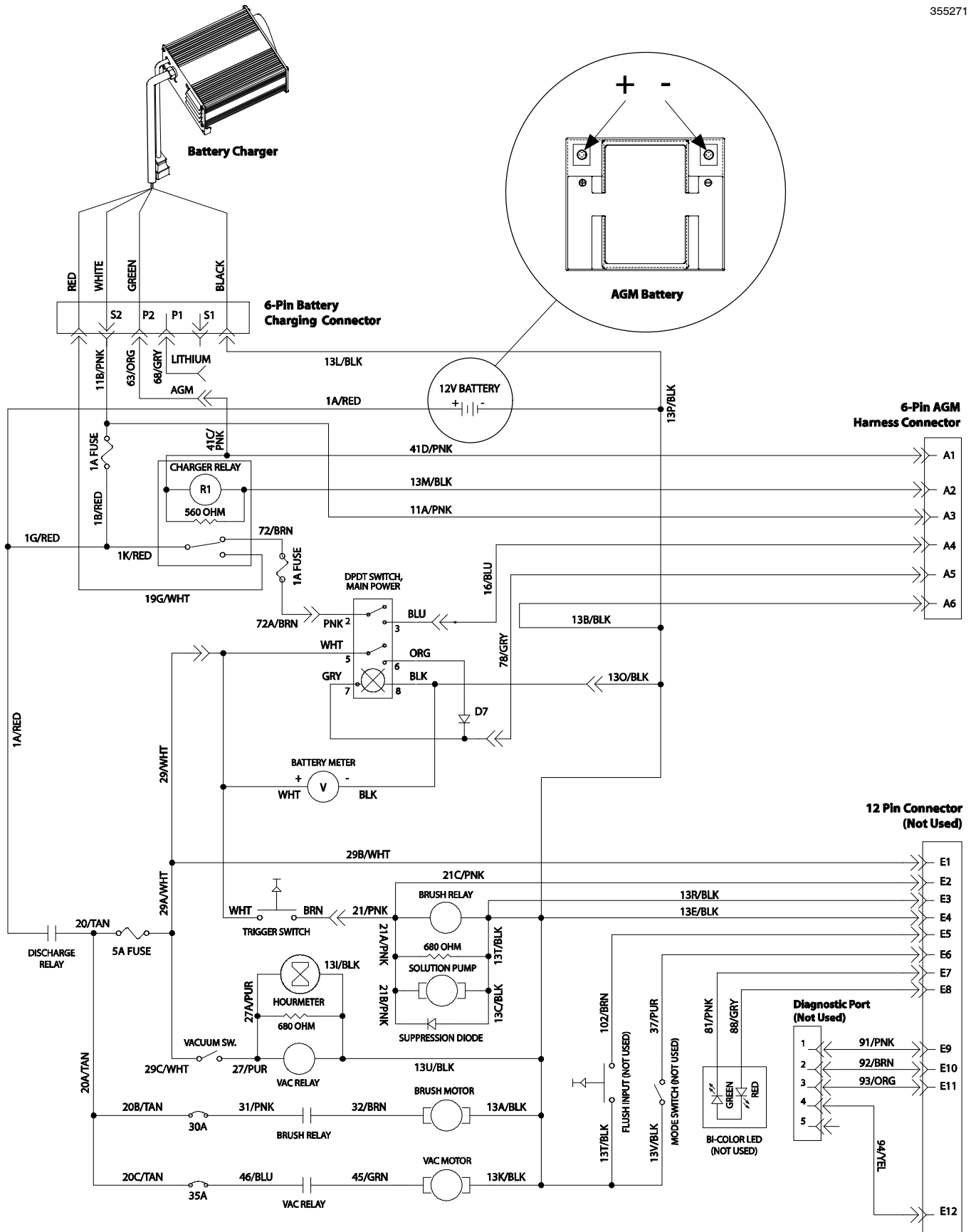

ELECTRICAL DIAGRAM, AGM BATTERY (Page 2 of 3)

355272

Late AGM Models (S/N: 11067408 - 20000000)

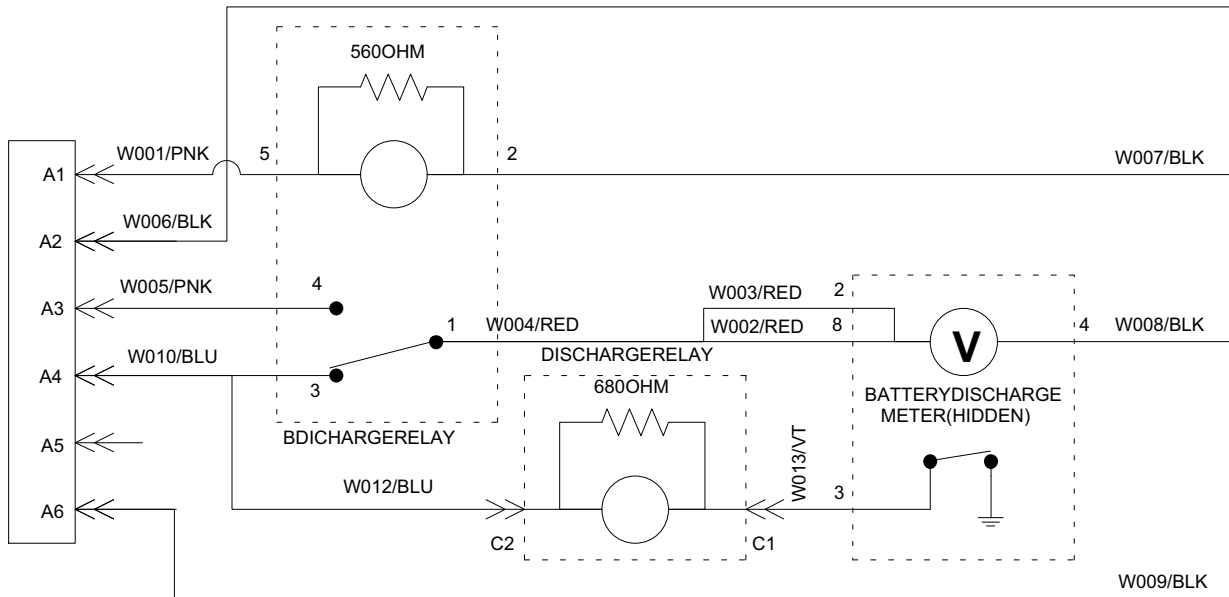

Late AGM Models (S/N: 10552860 - 11067407)

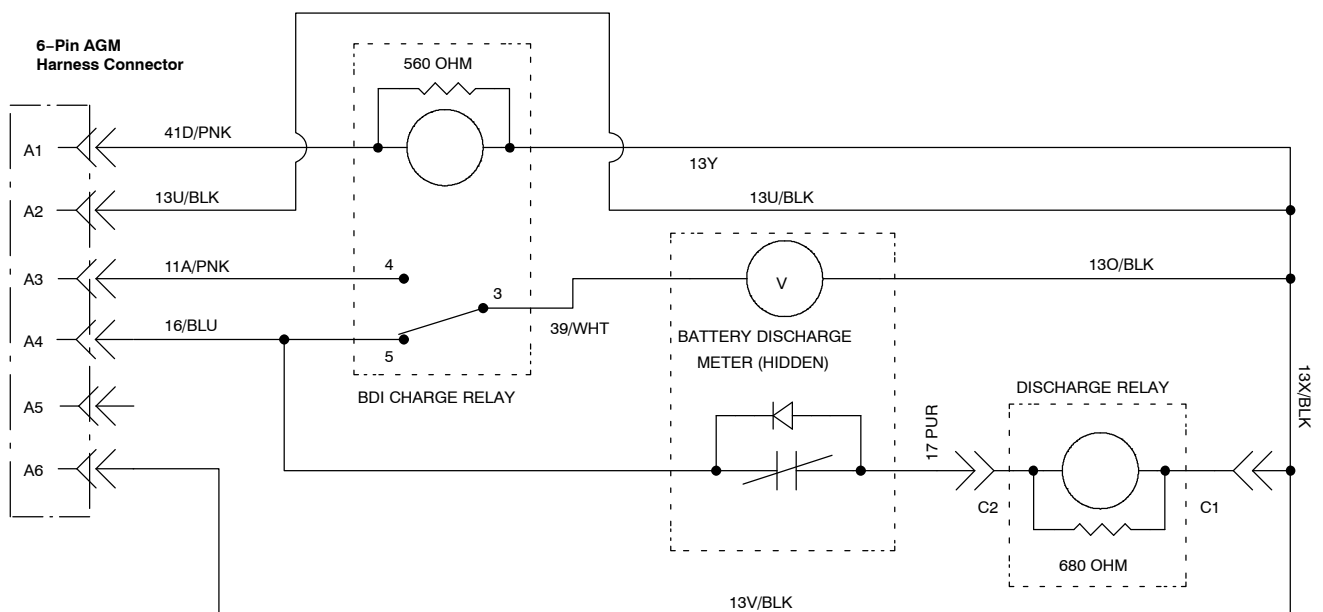

NOTE:
THIS BATTERY DISCHARGE METER IS USED AS A LOW VOLTAGE CUT-OFF RELAY ONLY. IT IS LOCATED BEHIND THE ACCESS COVER. CONTACTS OPEN AT ≤ 10.4 VOLTS.

ELECTRICAL DIAGRAM, AGM BATTERY (Page 3 of 3)

355272

Early AGM Models (S/N: 10000000 - 10552859)

6-Pin AGM
Harness Connector

NOTE:
THIS BATTERY DISCHARGE METER IS USED AS A LOW
VOLTAGE CUT-OFF RELAY ONLY. IT IS LOCATED BEHIND
THE ACCESS COVER. CONTACTS OPEN AT ≤ 10.4 VOLTS.

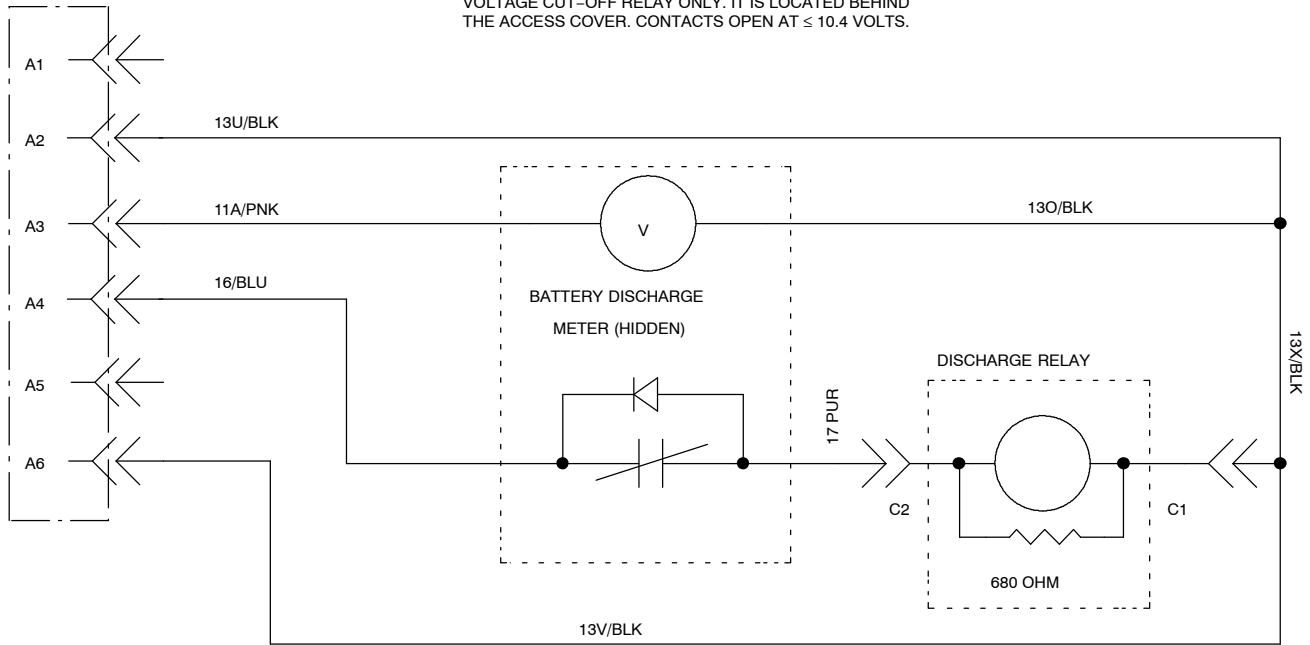

ELECTRICAL DIAGRAM, LITHIUM BATTERY (Page 1 of 2)

355273

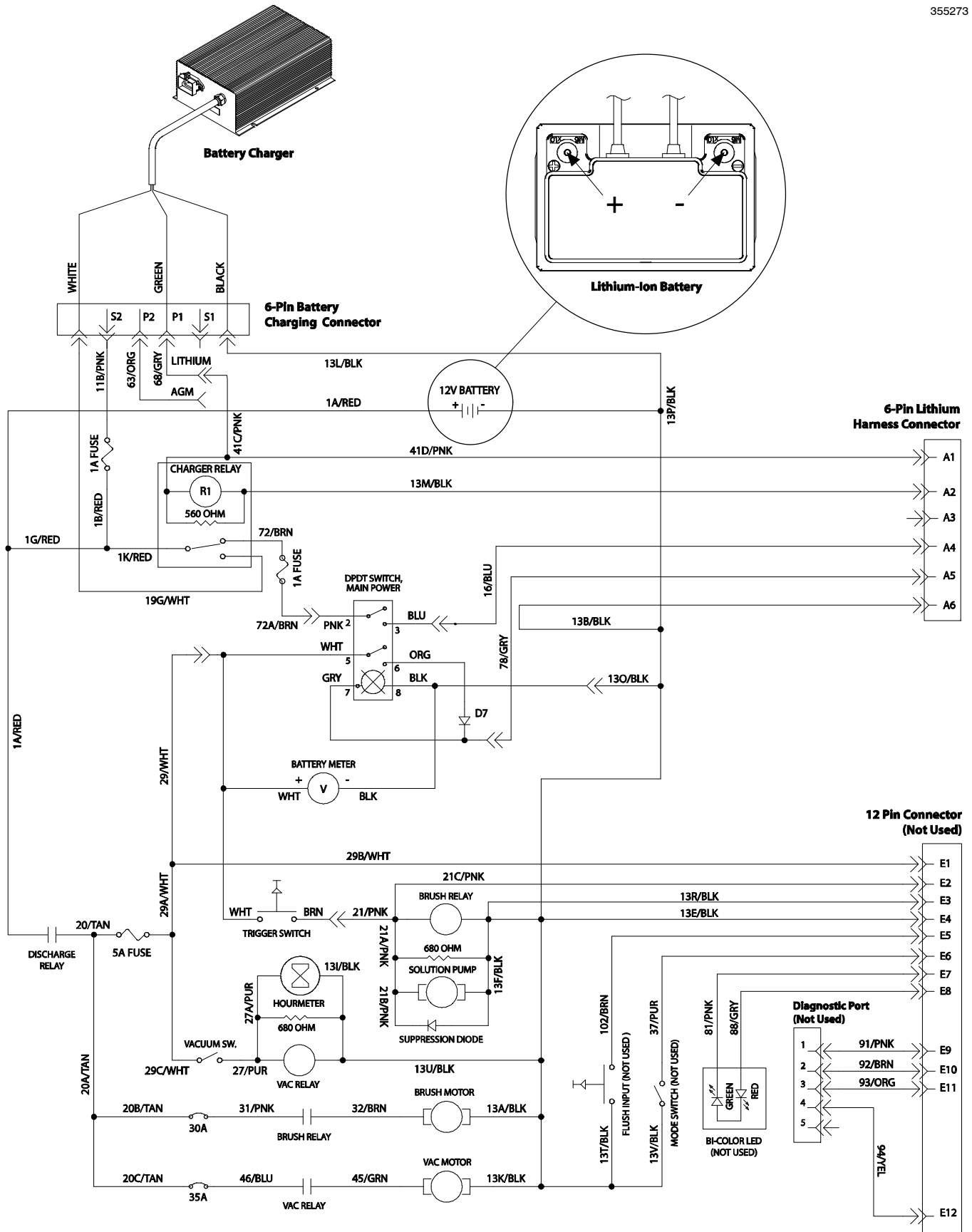

ELECTRICAL DIAGRAM, LITHIUM BATTERY (Page 2 of 2)

355274

**6-Pin Lithium
Harness Connector**

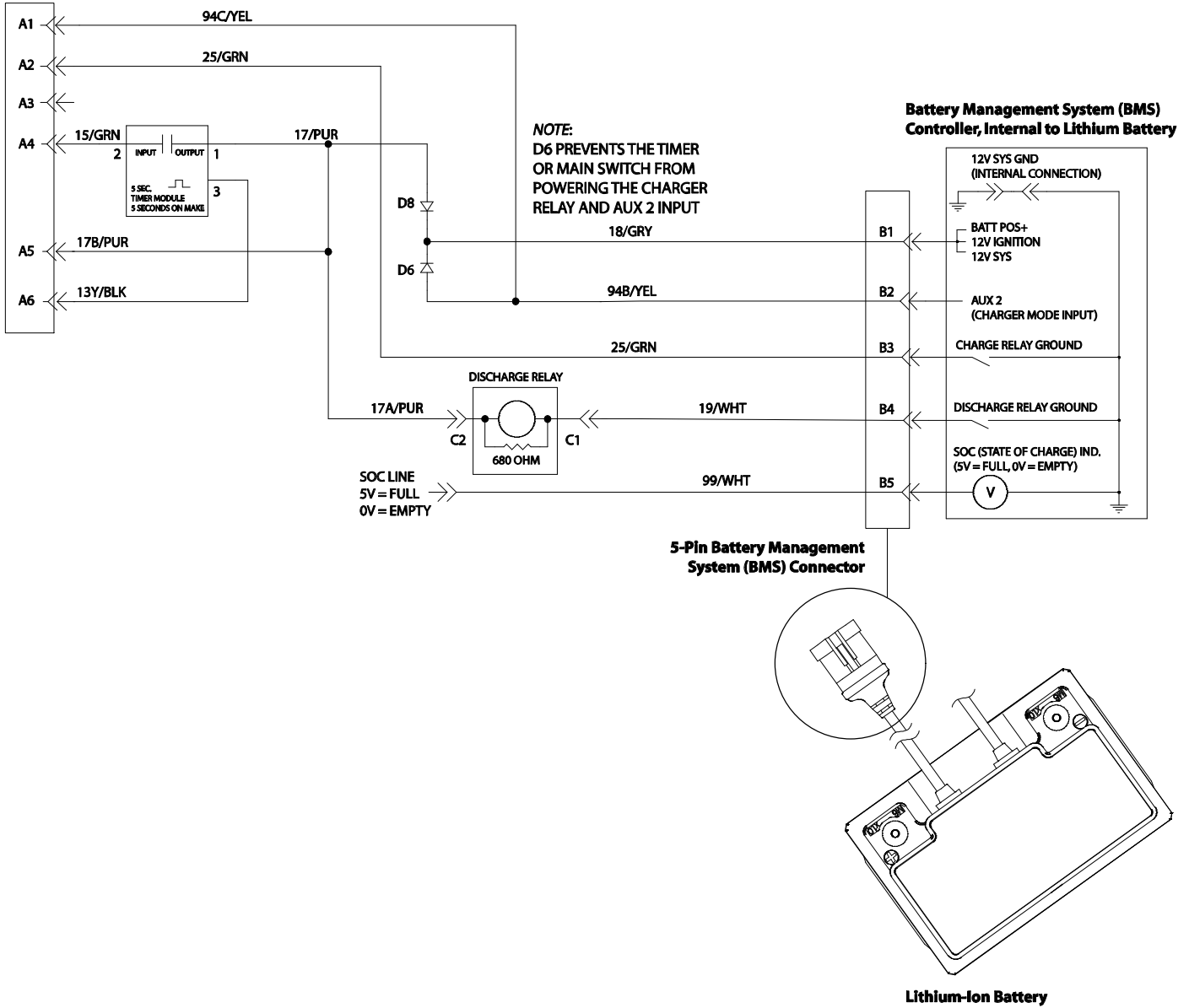

ELECTRICAL DIAGRAM, IRIS TELEMETRY OPTION

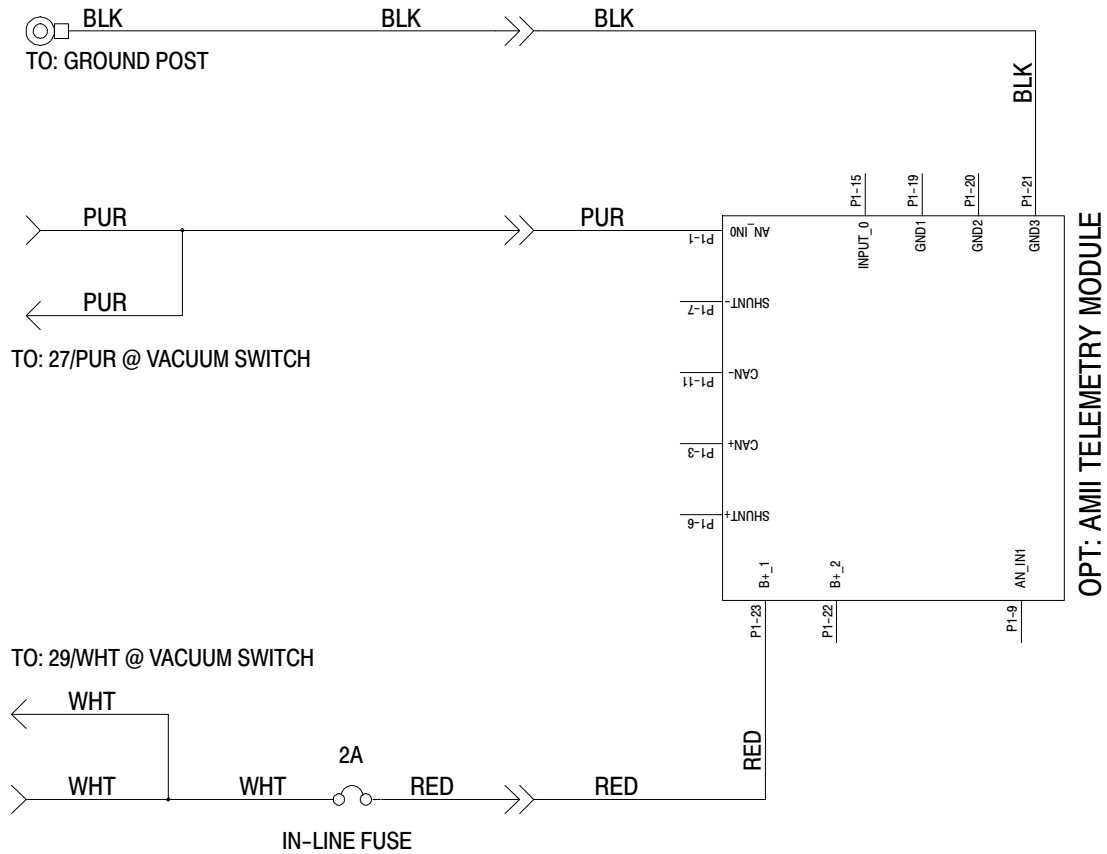

- NOTES:
- 29/WHT @ VACUUM SWITCH HAS VOLTAGE WHEN THE MACHINE IS TURNED ON.
 - 27/PUR @ VACUUM SWITCH HAS VOLTAGE WHEN THE VACUUM FAN IS TURNED ON.

OPTIONAL:
TELEMETRY ONLY

WIRE HARNESS, MAIN (S/N 10984379 -)

1076539_02

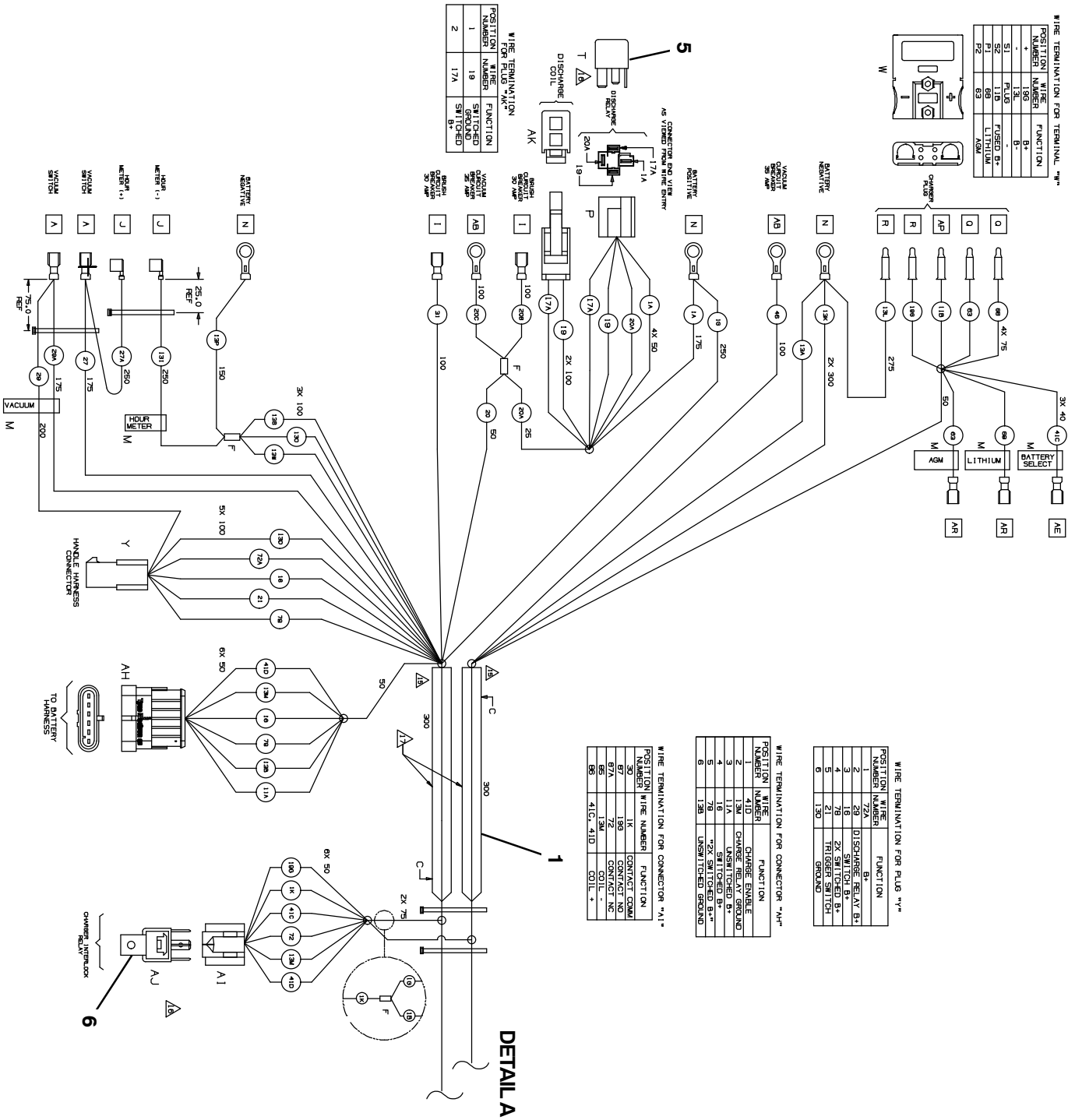

WIRE HARNESS, MAIN (S/N 10984379 -) - CONT'D

1076539_02

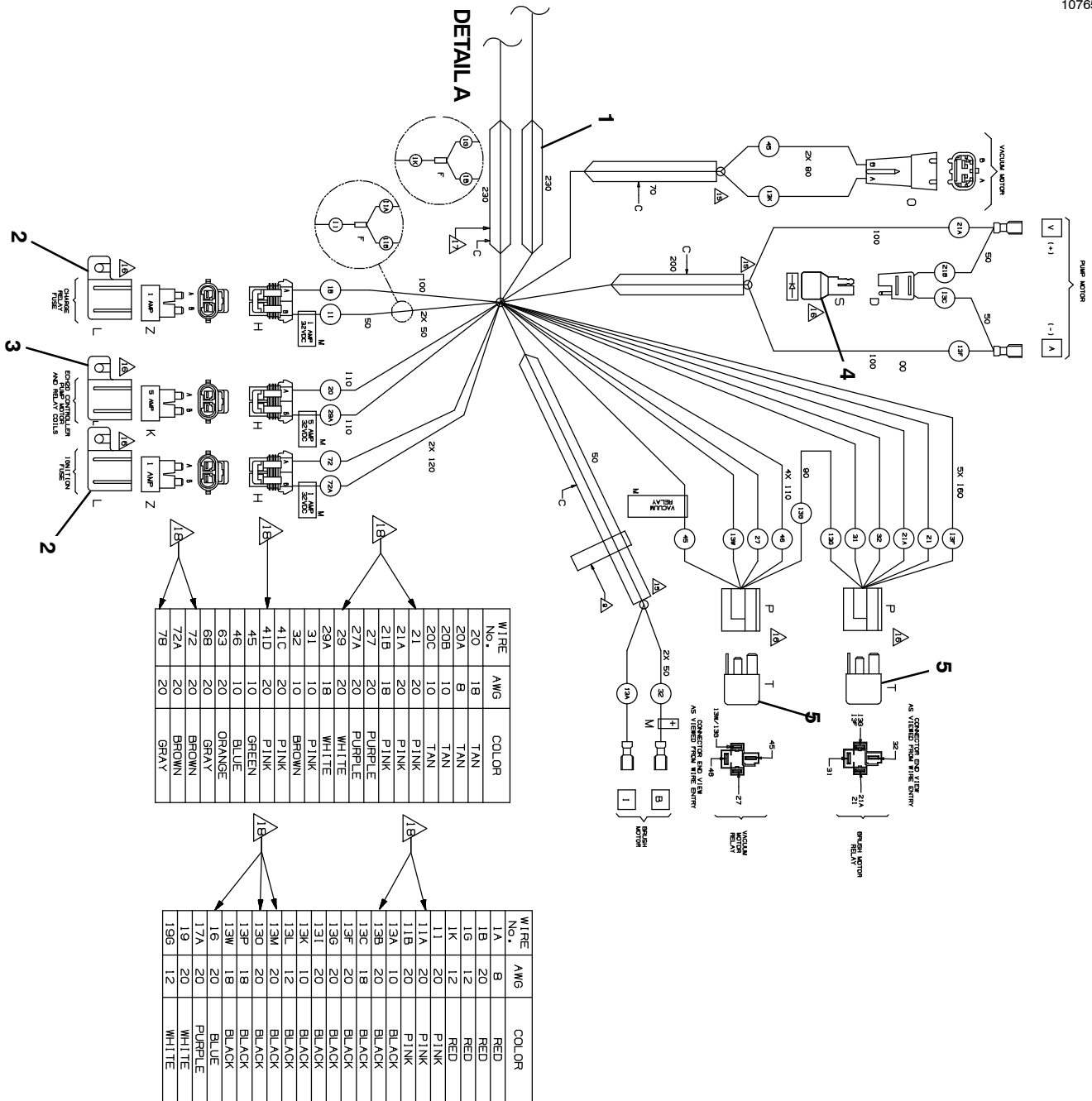

Ref.	Part No.	Serial Number	Description	Qty.
▽	1	1076539 (10984379-2000000)	Harness, Chassis, 12 Volt [T1b]	1
▲	2	1052127 (10000000-20000000)	Fuse, Blade, 001a, 32vdc	2
▲	3	1016029 (10000000-20000000)	Fuse, Blade, 005a, 32vdc	1
▲	4	222290 (10000000-20000000)	Diode, Ele, Plug	1
▲	5	1060940 (10000000-20000000)	Contractor, 12vdc, 080a, Spst, No	3
▲	6	1066293 (10000000-20000000)	Relay, 12vdc, 040a, Spdt	1

▽ ASSEMBLY

▲ INCLUDED IN ASSEMBLY

WIRE HARNESS, MAIN (S/N 1000000 - 10984378)

355146

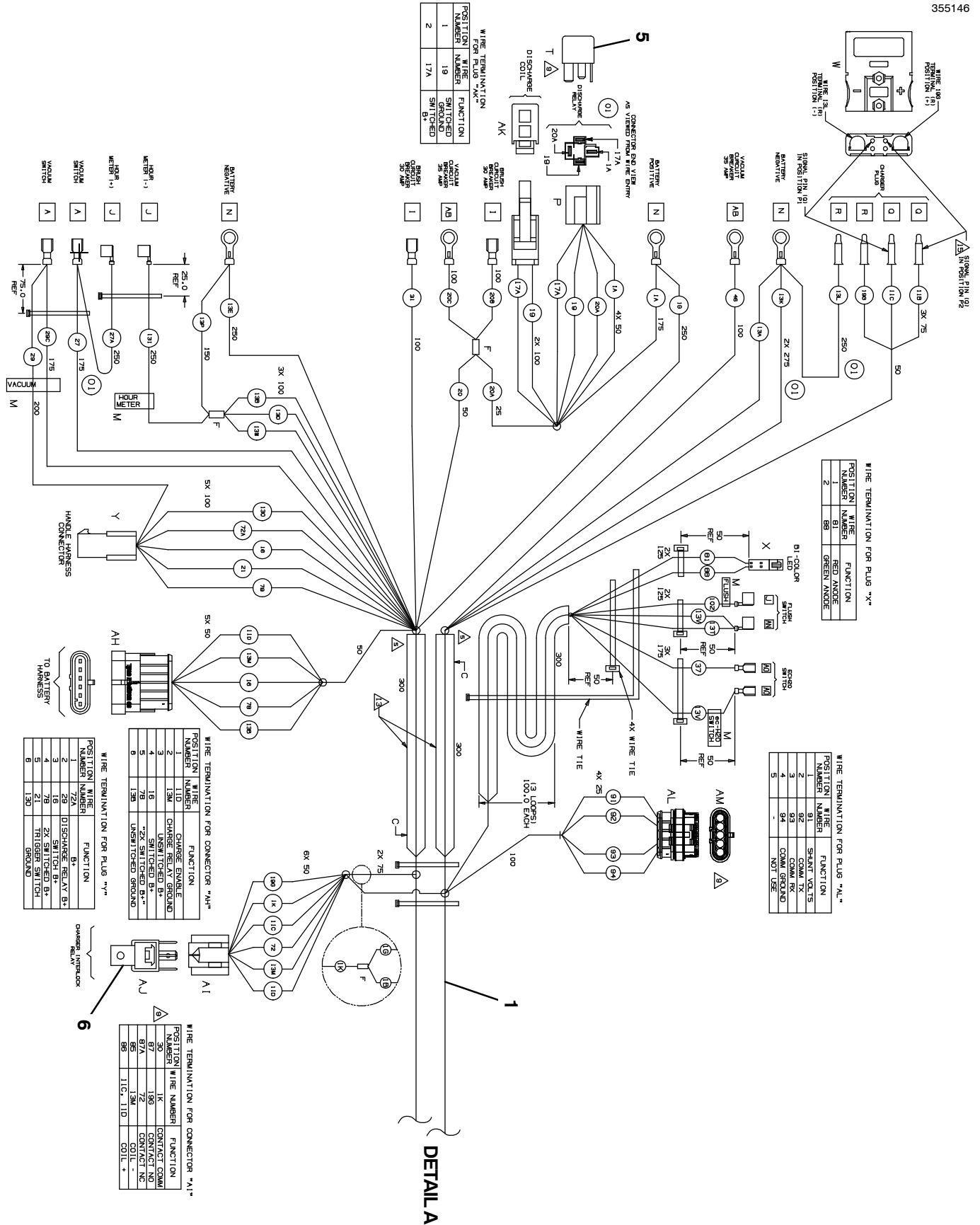

WIRE HARNESS, MAIN (S/N 1000000 - 10984378) - CONT'D

355147

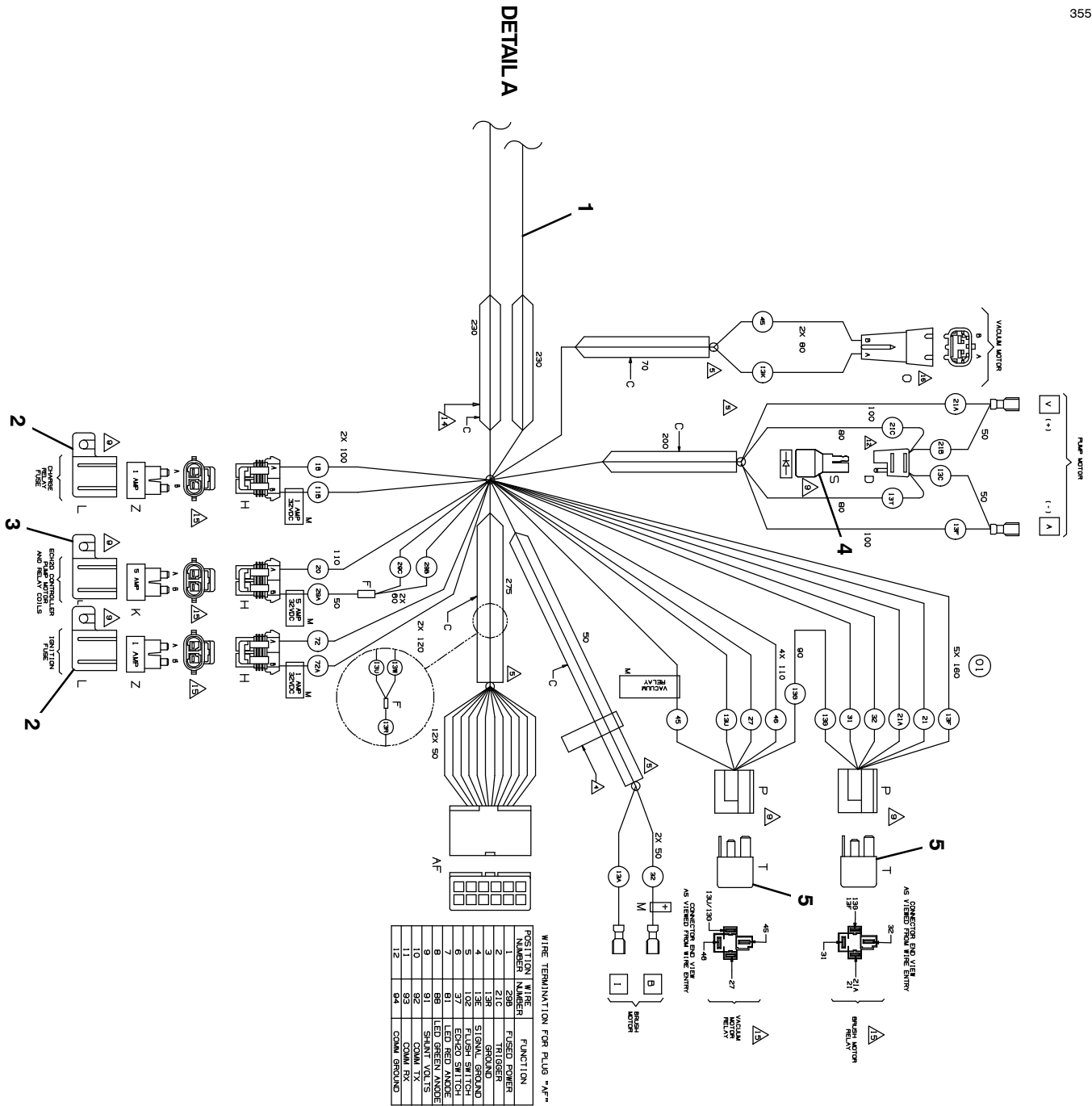

Ref.	Part No.	Serial Number	Description	Qty.
▽	1	1064897 (1000000-2000000)	Harness, Chassis, 12 Volt [T1b]	1
▲	2	1052127 (1000000-2000000)	Fuse, Blade, 001a, 32vdc	2
▲	3	1016029 (1000000-2000000)	Fuse, Blade, 005a, 32vdc	1
▲	4	222290 (1000000-2000000)	Diode, Ele, Plug	1
▲	5	1060940 (1000000-2000000)	Contact, 12vdc, 080a, Spst, No	3
▲	6	1066293 (1000000-2000000)	Relay, 12vdc, 040a, Spdt	1

▽ ASSEMBLY

▲ INCLUDED IN ASSEMBLY

WIRE HARNESS, JUMPER (LITHIUM)

355148

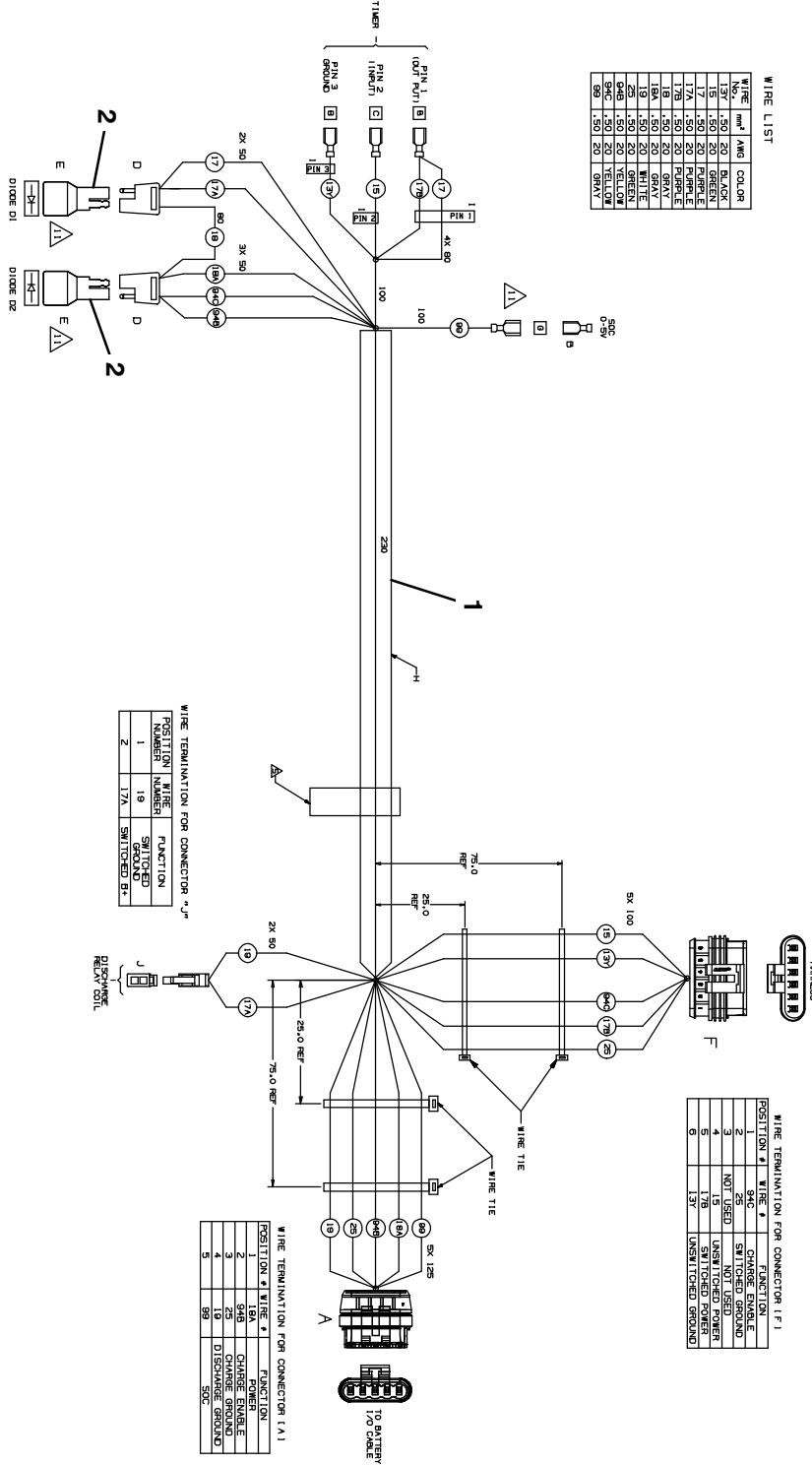

Ref.	Part No.	Serial Number	Description	Qty.
▽	1	1063936	(10000000-20000000) Harness, Jumper [Phantom Pi Lithium]	1
▲	2	222290	(10000000-20000000) Diode, Ele, Plug	2

▽ ASSEMBLY
 ▲ INCLUDED IN ASSEMBLY

WIRE HARNESS, JUMPER (AGM) (S/N 11067408 – 2000000)

1266170_00

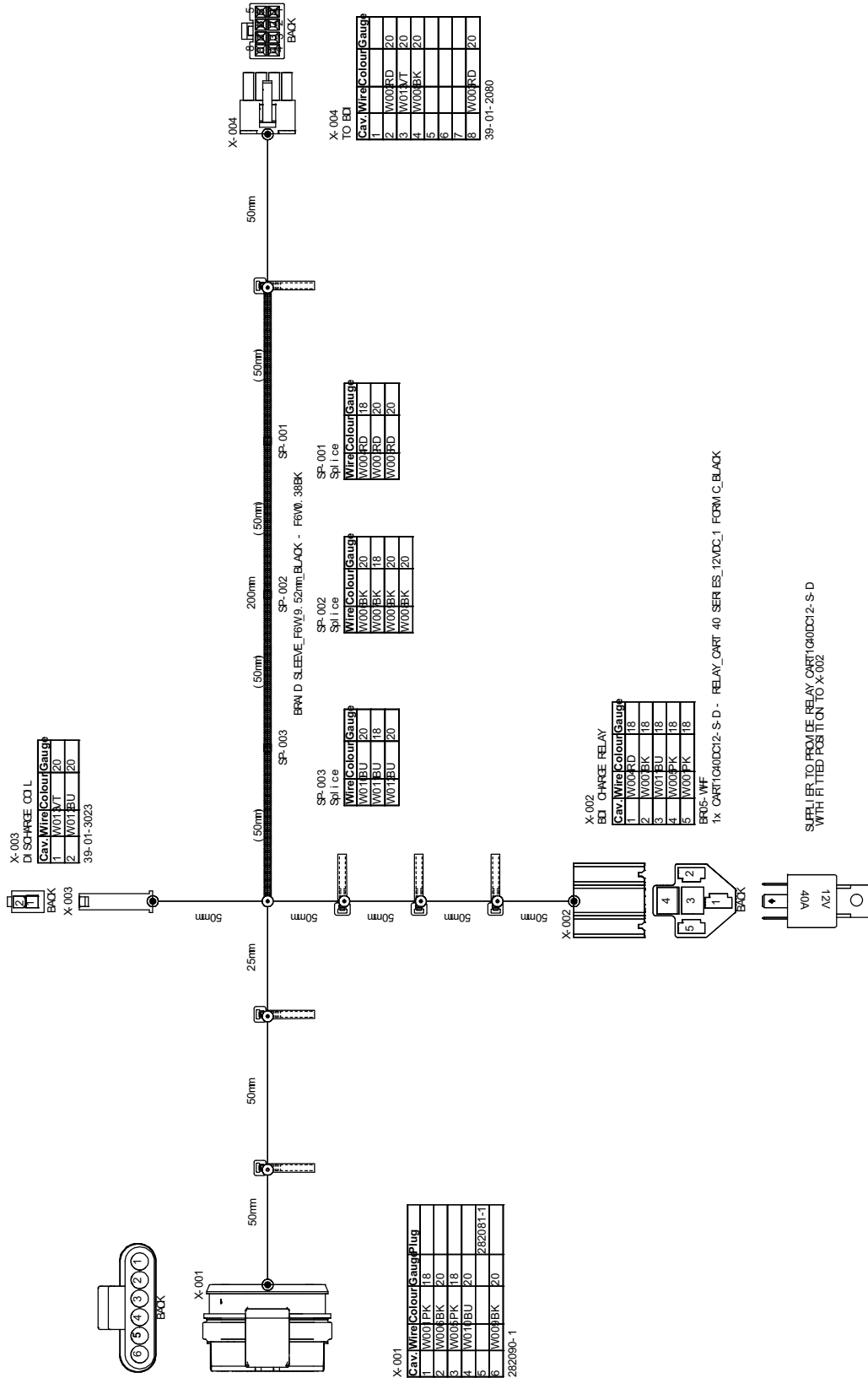

Ref.	Part No.	Serial Number	Description	Qty.
1	1266170	(11067408-2000000)	Harness, Ele, Jumper [Phantom Agm/Tpp]	1

WIRE HARNESS, JUMPER (AGM) (S/N 10552859 – 11067407)

355270

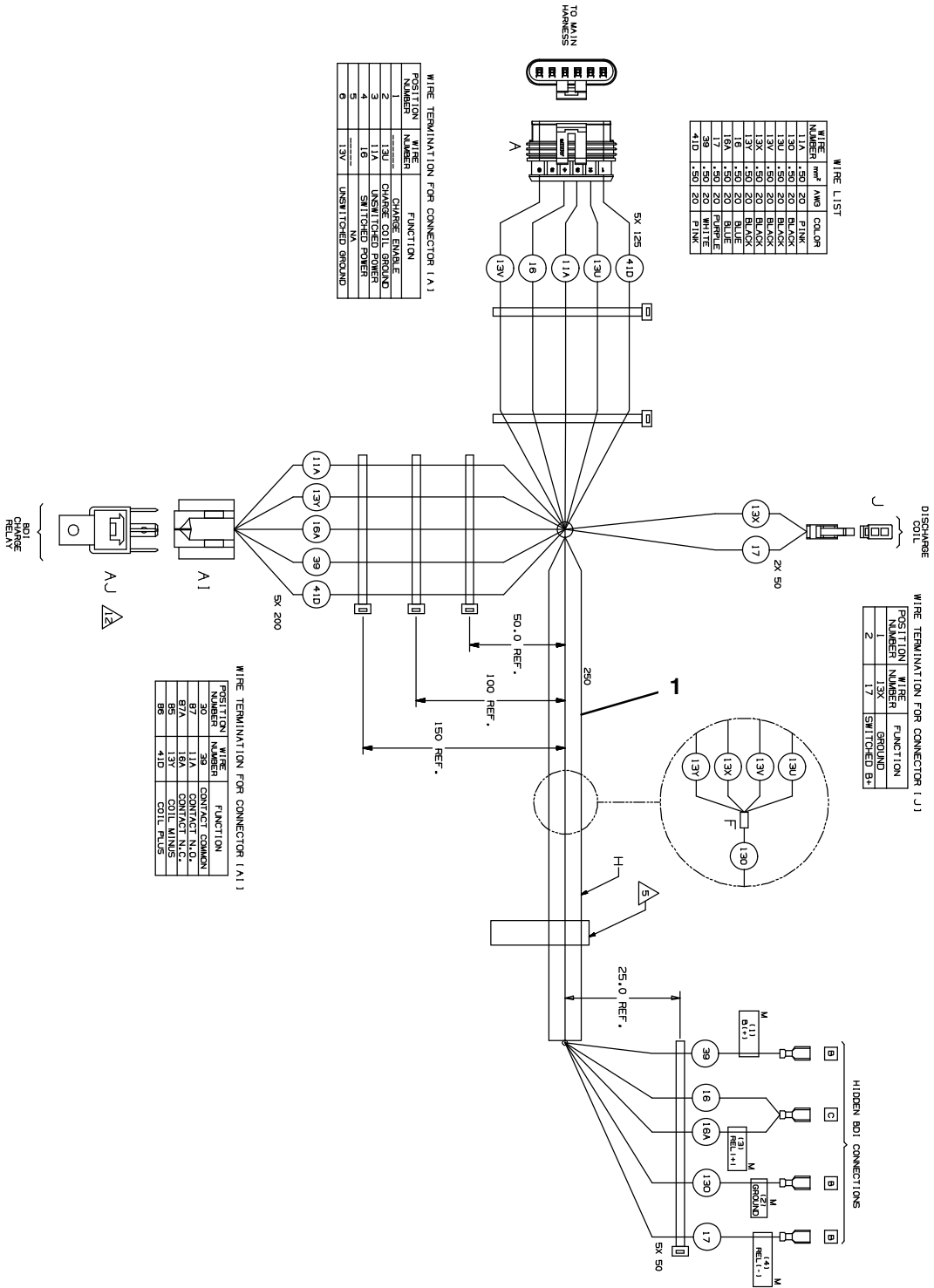

Ref.	Part No.	Serial Number	Description	Qty.
1	1069703	(10552860-11067407)	Harness, Jumper [Phantom Agm / Tpp]	1

355149

WIRE HARNESS, JUMPER (AGM) (S/N 1000000 – 10552859)

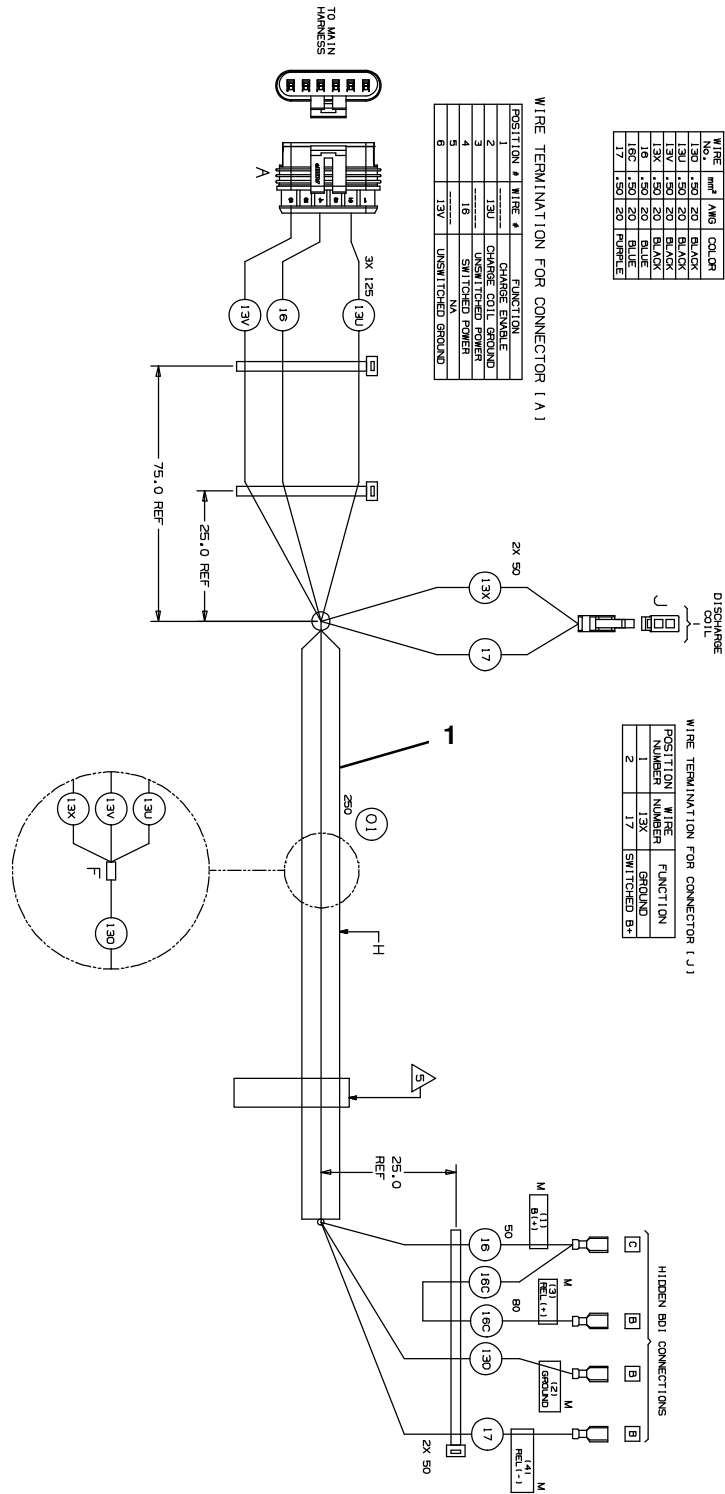

Ref.	Part No.	Serial Number	Description	Qty.
1	1064899	(1000000-10552859)	Harness, Jumper [Phantom Agm / Tppl] (Replaced by 1069703)	1

WIRE HARNESS, IRIS TELEMETRY

355590

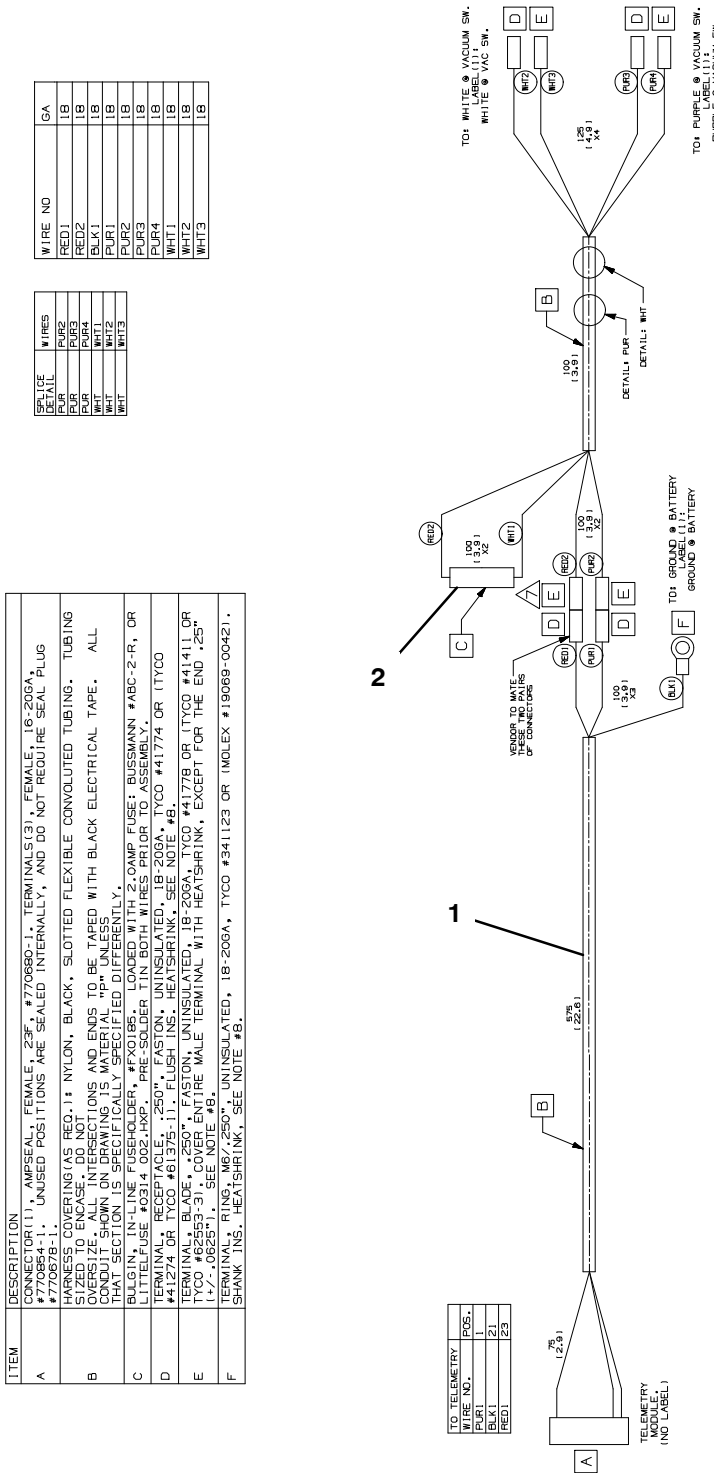

	Ref.	Part No.	Serial Number	Description	Qty.
▽	1	1075891	(1000000-2000000)	Cs, Harness, Ele [Telem, T1b / Ss]	1
▲	2	9009990	(1000000-2000000)	Vr, Fuse, 002a, 250vdc, Cartridge	1

- ▽ ASSEMBLY
- ▲ INCLUDED IN ASSEMBLY

IRIS TELEMETRY GROUP

355589

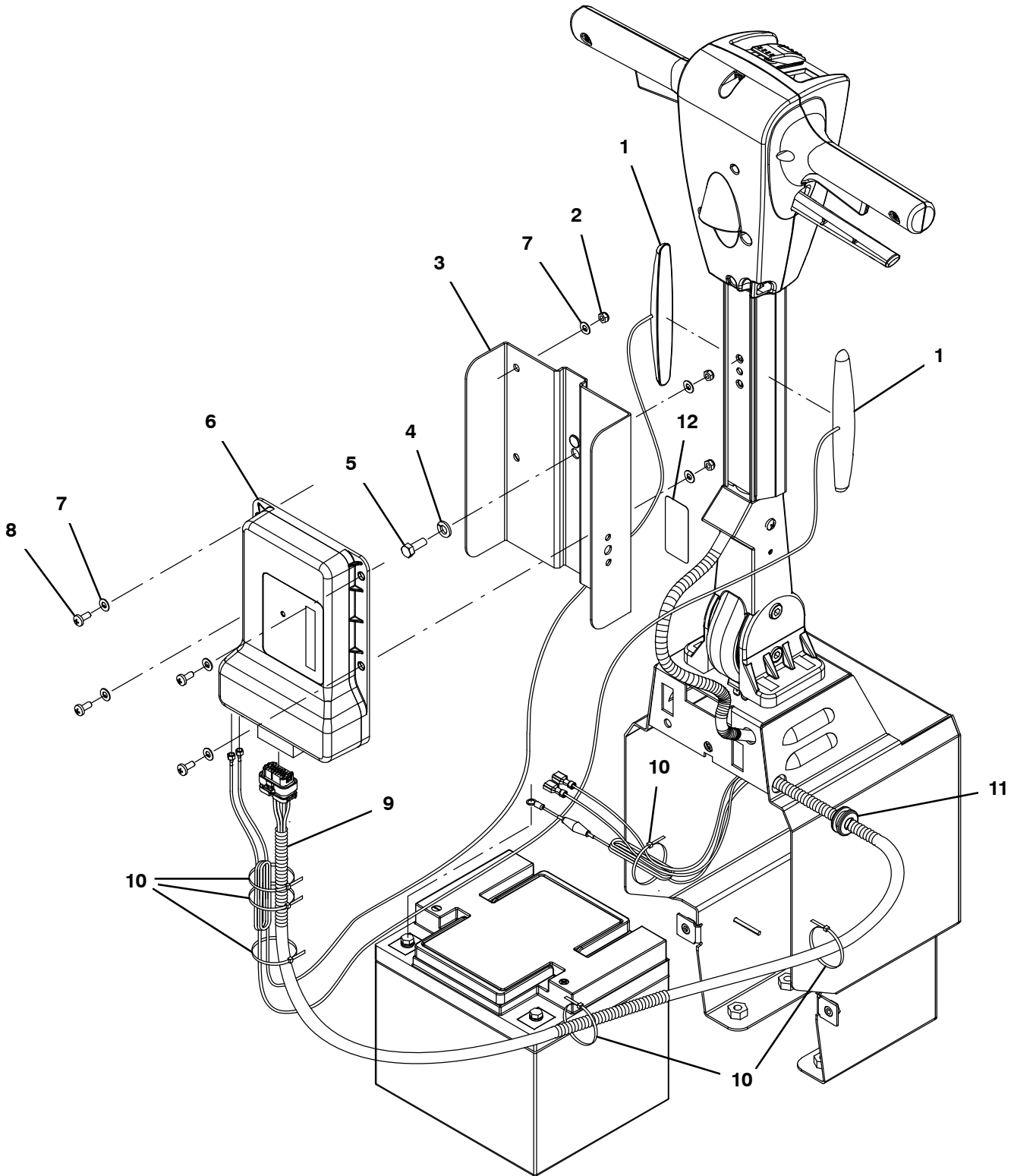

IRIS TELEMETRY GROUP

Ref.	Part No.	Serial Number	Description	Qty.	
1	1247569	(11016001-20000000)	Antenna, Telem [4g, 36]	2	
1	1070659	(10000000-11016000)	Antenna, Telem, 70 In [Gprs] (Replaced By 1247569)	1	
2	09739	(10000000-20000000)	Nut, Hex, Lock, M5 X 0.80, NI, Ss	4	
3	1233223	(10000000-20000000)	Cs, Plate Wldt, Mount [Iris, Trex]	1	
4	140015	(10000000-20000000)	Washer, Lock, Split, 0.31, Ss	1	
5	140226	(10000000-20000000)	Screw, Hex, .31-18 X 0.62, Ss	1	
6	1247507	(11016001-20000000)	Controlbox Assy, Telem [Usa, 4g]	1	
6	1069467	(10000000-11016000)	Controlbox Assy, Telem [Usa, 3g] (Replaced By 1247507 & Qty 2 of Antenna 1247569)	1	
7	140011	(10000000-20000000)	Washer, Flat, 0.21b 0.45d .03, Ss	8	
8	09200	(10000000-20000000)	Screw, Pan, Phl, M5 X 0.80 X 12, Ss	4	
∇	9	1075891	(10000000-20000000)	Cs, Harness, Ele [Telem, T1b / Ss]	1
▲		9009990	(10000000-20000000)	Vr, Fuse, 002a, 250vdc, Cartridge	1
	10	130773	(10000000-20000000)	Tie, Cable, Nyl, 11.0l, .14w, 3.0 Max. D	6
	11	86726	(10000000-20000000)	Grommet, Rbr, 0.44id, F/0.5h, .19 Matl	1
	12	1076671	(11016001-20000000)	Label, Mach, Telem [Usa, 4g]	1
	12	1069580	(10000000-11016000)	Label, Mach, Telem [Usa, Intl]	1

∇ ASSEMBLY

▲ INCLUDED IN ASSEMBLY

BATTERY CONVERSION KIT (AGM TO LITHIUM)

355152

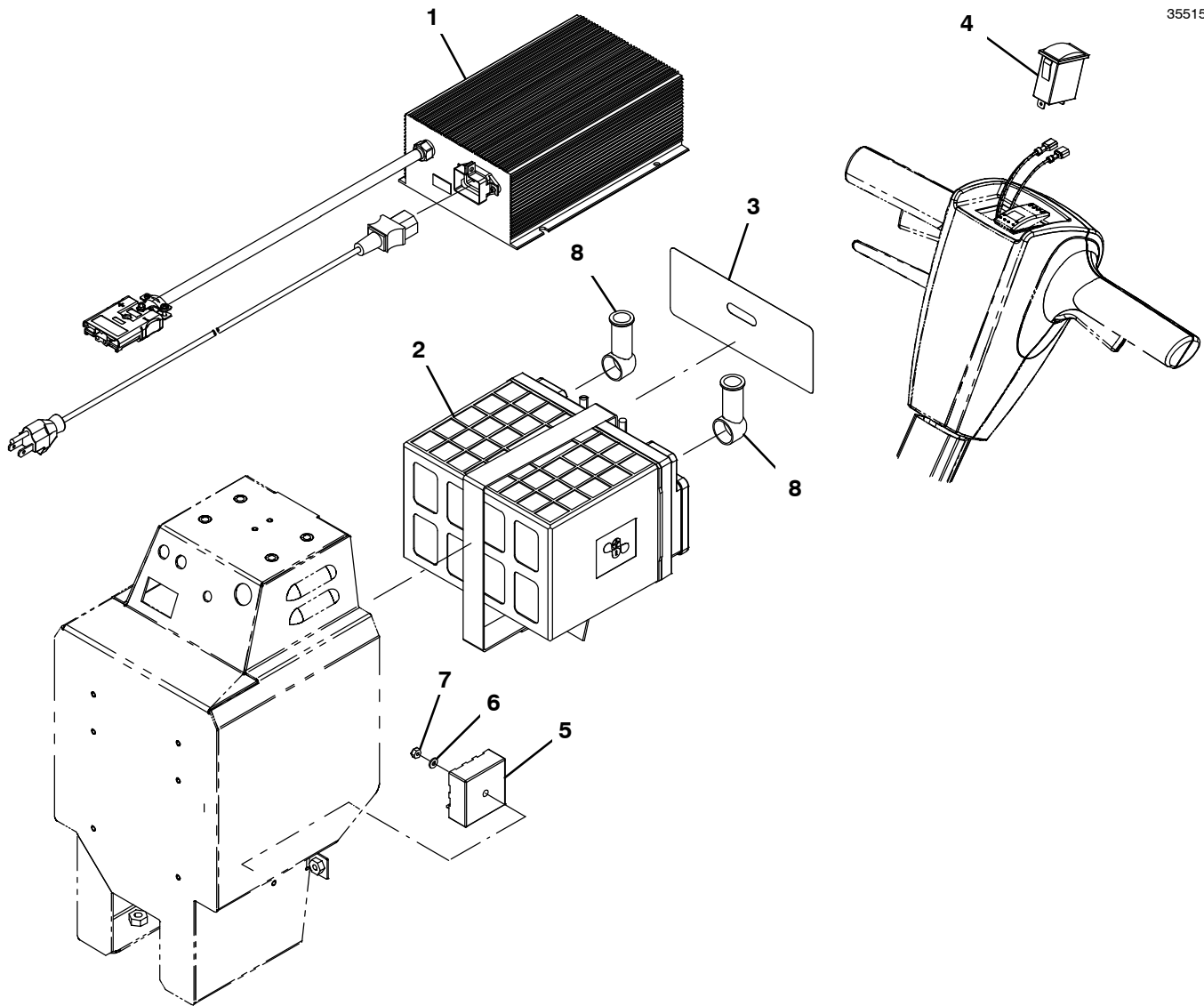

Ref.	Part No.	Serial Number	Description	Qty.
▽	9008723	(10000000-20000000)	Kit, Battery Conv, W/Bat [Agm To Li+]	1
▽	9008689	(10000000-20000000)	Battery Kit, Conv. W/O Bat [Agm To Li+] (Kit Does NOT Contain Battery Item #2)	1
▲	1 1065754	(10000000-20000000)	Charger, 12vdc, 16a, 120/240vdc [Li-Ion]	1
▲▽	2 9008690	(10000000-20000000)	Battery Replmt Kit, [Li+]	1
▲▲	3 1067699	(10000000-20000000)	Label, Battery, Li-Ion	2
▲	4 1048378	(10000000-20000000)	Gauge, Voltmeter, 12vdc Nominal	1
▲	5 1053209	(10000000-20000000)	Module, Timer, 12v, 5s Interval	1
▲	6 41578	(10000000-20000000)	Washer, Flat, 06, Ss	1
▲	7 75939	(10000000-20000000)	Nut, Hex, Lock, #06-32, NI	1
▲	N/S 1063936	(10000000-20000000)	Harness, Jumper [Phantom Pi Lithium]	1
	8 611221	(10000000-20000000)	Boot, Terminal, Battery, 25.4mm, Blk	2

▽ ASSEMBLY

▲ INCLUDED IN ASSEMBLY

BATTERY CONVERSION KIT (LITHIUM TO AGM)

355153

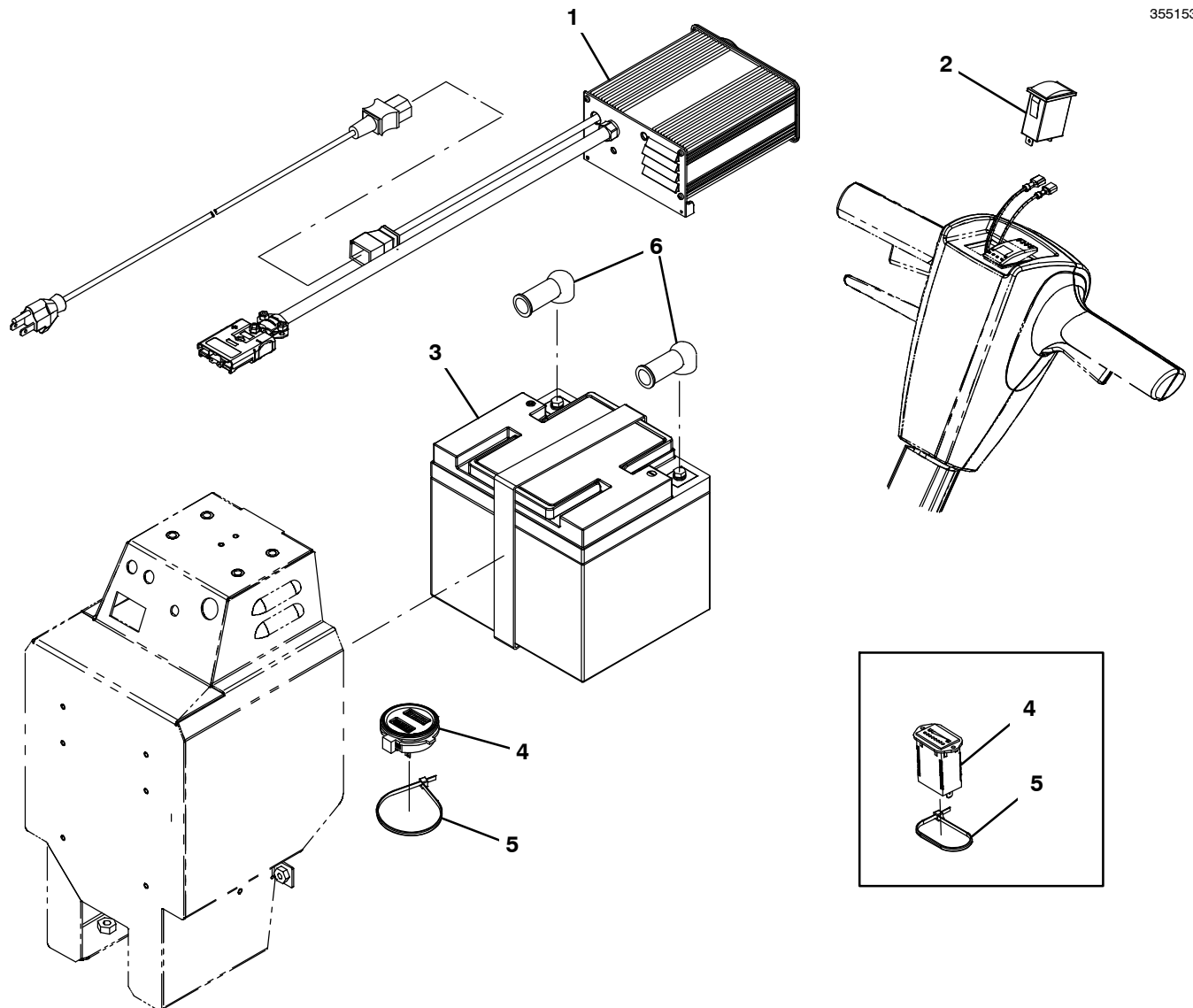

	Ref.	Part No.	Serial Number	Description	Qty.
▽		9008688	(10000000-20000000)	Battery Exchange Kit [Li+ To Agm]	1
▲	1	1067790	(10000000-20000000)	Charger, Battery, 12vdc [Spe Eu & Na]	1
▲	2	1065438	(10000000-20000000)	Gauge, Voltmeter, 12vdc Nominal [Agm]	1
▲	3	1065086	(10000000-20000000)	Battery, 12vdc 0050ah	1
▲	4	1265929	(11067408-20000000)	Gauge, Hour, Battery (AGM Model)	1
	4	1064516	(10000000-11067407)	Indicator, Battery, 12vdc, 1.73volt/Cell (AGM Model) (Replaced By Kit 9022666)	1
▲	5	130773	(10000000-20000000)	Tie, Cable, Nyl, 11.0l, .14w, 3.0 Max. D	1
▲	N/S	1266170	(11067408-20000000)	Harness, Ele, Jumper [Phantom Agm/Tpp]	1
	N/S	1069703	(10552860-11067407)	Harness, Jumper [Phantom Agm / Tpp]	1
	N/S	1064899	(10000000-10552859)	Harness, Jumper [Phantom Agm / Tpp] (Replaced by 1069703)	1
	6	611221	(10000000-20000000)	Boot, Terminal, Battery, 25.4mm, Blk	2

▽ ASSEMBLY

▲ INCLUDED IN ASSEMBLY

DOCUMENTATION GROUP (ONLINE ONLY)

Ref.	Part No.	Serial Number	Description	Qty.
	9008730	(10000000-20000000)	Manual, Parts [Speedscrub Batt 15"]	1
	9008731	(10000000-20000000)	Manual, Oprtr [Ss Batt 15" En/ Es/ Fr]	1
	9008918	(10000000-20000000)	Instr, Use&Care, Wallchart [Ss15b]	1
	9008976	(10000000-20000000)	Manual, Service [Ssb]	1



To view, print, order, download the latest Parts manual, other language Operator manuals, and Use and Care Guides (wall charts), visit:

www.nobles.com/manual

